

# APPLICATION SPECIFIC, CUSTOM DESIGN & HIGH PERFORMANCE FILMS

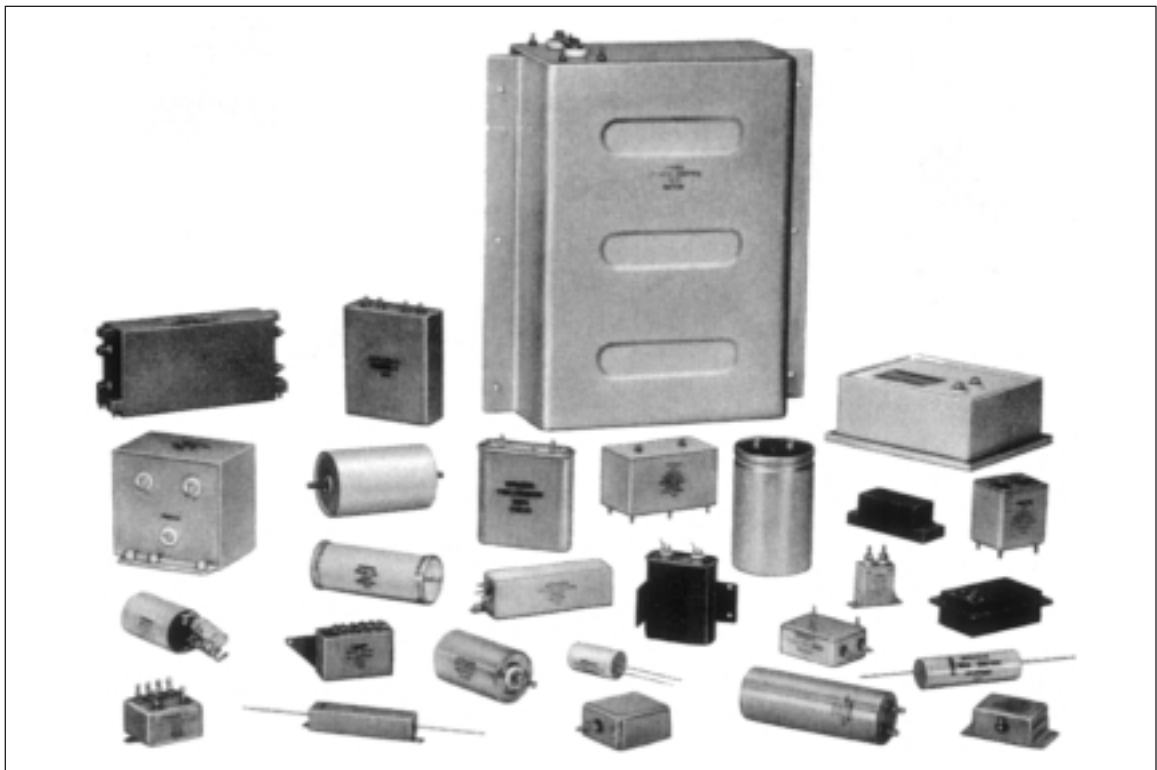

<b>Typical Custom designed Capacitors Manufactured by Dearborn . . . . .</b>	<b>G-2</b>
<b>Application Specific Design. . . . .</b>	<b>G-2</b>
<b>High Performance Films . . . . .</b>	<b>G-3</b>
<b>Metalized Monolithic Polymer Film Capacitors . . . . .</b>	<b>G-4</b>
Type 520P. . . . .	G-4

## CUSTOM-DESIGNED FILM AND PAPER CAPACITORS

Tailoring of capacitors to meet special requirements for geometry and electrical characteristics is often necessary. Dearborn Electronic Inc. supplies “special” capacitors

utilizing a wide variety of dielectrics in many different mechanical configurations. The photograph below illustrates typical capacitors tailored to meet specific application needs.

### TYPICAL CUSTOM-DESIGNED CAPACITORS BUILT BY DEARBORN ELECTRONICS INC.

1. Metalized Paper-Polyester, 350 $\mu$ F to 385 $\mu$ F, 3300 VDC peak
2. Metalized Paper-Polyester, 160 $\mu$ F, 1600 VDC peak
3. Metalized Paper-Polyester, 25 $\mu$ F, 1600 VDC peak
4. Paper Polyester-Foil, 2 x 0.05 $\mu$ F, 16,500 VDC
5. Metalized Polycarbonate, 26 $\mu$ F  $\pm$  2%, 180 V RMS, 400 Hz
6. Metalized Polycarbonate, 40 $\mu$ F  $\pm$  2%, 115 V RMS, 400 Hz
7. Polyester-Foil, 4.0 $\mu$ F  $\pm$  5%, 2000 VDC
8. Polyester-Foil, 1.0 $\mu$ F  $\pm$  10%, 350 VAC
9. Paper-Polyester-Foil, 0.20 $\mu$ F  $\pm$  20%, 10,000 VDC
10. Metalized Polycarbonate, 8 x 1.0 $\mu$ F  $\pm$  10%, 150VDC; 2 x 1.0 $\mu$ F  $\pm$  10%, 200 VDC
11. Metalized Polyester, 11 $\mu$ F  $^{+25}_{-0}$ % 750 VDC peak
12. Polyester-Foil, 1.8 $\mu$ F +16.2 $\mu$ F  $\pm$  10%, 50 VDC
13. Metalized Polycarbonate 28 $\mu$ F  $\pm$  5%, 40V RMS, 400 Hz; 0.27 $\mu$ F  $\pm$  5%, 600 VDC; 0.47 $\mu$ F  $\pm$  5%, 600 VDC
14. Polyester-Foil, .057 $\mu$ F  $\pm$  10%, 400 VDC, 115 VAC, 400 Hz
15. Metalized Paper-Polyester, 1.0 $\mu$ F  $\pm$  10%, 2500 VDC

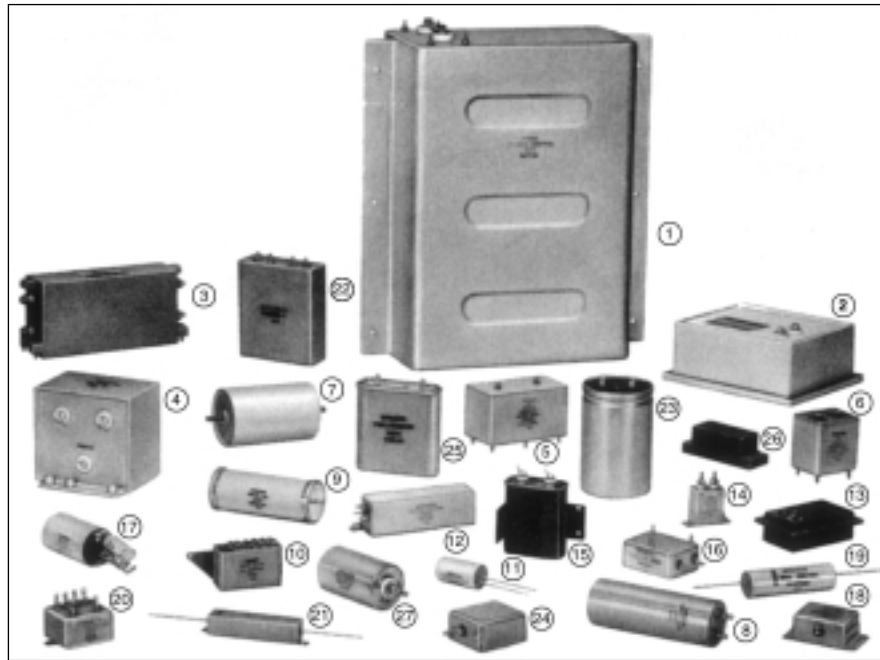

16. Polyester-Foil, 10.0 $\mu$ F  $\pm$  10%, 30 VDC
17. Polyester-Foil, 0.20 $\mu$ F  $\pm$  10%, 6000 VDC
18. Metalized Polycarbonate, 8 $\mu$ F  $\pm$  10%, 120 V RMS, 400 Hz
19. Metalized Polyvinylidene Fluoride 80 $\mu$ F  $\pm$  10%, 250 VDC
20. Polystyrene-Foil 0.864 $\mu$ F  $\pm$  1%, 50 VDC; 0.115 $\mu$ F  $\pm$  1%, 50 VDC; 0.735 $\mu$ F  $\pm$  1%, 50 VDC; 0.098 $\mu$ F  $\pm$  1%, 50 VDC
21. Metalized Polyvinylidene Fluoride 40 $\mu$ F  $^{+15}_{-25}$ %, 250 VDC
22. Metalized Polysulfone, 60 $\mu$ F  $\pm$  5%, 204 RMS
23. Metalized Paper-Polyester, 30 $\mu$ F  $^{+20}_{-10}$ %, 3000 VDC
24. Metalized Polycarbonate, 30 $\mu$ F  $\pm$  10%, 150 VAC, 400 Hz
25. Polycarbonate-Foil, 1.5 $\mu$ F  $\pm$  5%, 330 VAC
26. Paper-Polyester-Foil 0.02 $\mu$ F  $\pm$  10%, 10,000 VDC
27. Metalized-Polyester, 22 $\mu$ F  $\pm$  5%, 1200 V

## CUSTOM DESIGN

Various dielectrics used have been paper, paper-polyester, polyester, polycarbonate, polysulfone, polystyrene, polypropylene, TFE fluorocarbon, polyvinylidene fluoride, and others. Capacitors have been produced using the discrete foil and metalized electrode systems. Impregnants employed include mineral oil, wax, Vitamin Q® silicone oil and various so-called solid impregnants.

Capacitor housings include drawn and fabricated metal shells in standard, rectangular, and special shapes, glass and ceramic tubes, cast epoxy housings, molded housings, plastic-film tubes, plastic-film wraps, and epoxy and resin coatings. Where required, special mounting studs and brackets have been furnished.

Capacitance tolerances to meet specific application needs are available within the limits of the capacitor construction. Units with matched capacitor sections, multiple sections of different dielectrics, pulse forming networks, capacitor networks, capacitor standards, or other application specific capacitors, are available to meet your circuit needs.

Special paper and film-type capacitors have been provided with capacitance ratings from 0.0001 $\mu$ F to 2000 $\mu$ F and with voltage ratings from 30 VDC to 30,000 VDC. Capacitors have been supplied to operate over the temperature range of -65°C to +200°C.

The rigid quality control exercised by Dearborn Electronics Inc. on all its standard production is also applied to custom-fabricated capacitors. Where necessary, special testing is done to verify requirements, such as low dielectric absorption, ultra-high insulation resistance, low dissipation factor, stability under temperature cycling or under specified environmental conditions, etc.

If you have need for special capacitor designs utilizing paper or film dielectrics, Dearborn will be glad to make recommendations on how best to meet your application needs.

## HIGH PERFORMANCE FILMS

Dearborn evaluates new dielectrics as they become available and has been a leader in the introduction of new film capacitor types.

There are some specialty dielectrics available today which offer significant improvement in electrical or physical characteristics. They are as follows:

Polyvinylidene Fluoride	(PVDF)
Polyethylene Naphthalate	(PEN)
Fluorene Polyester	(FPE)

PVDF has a dielectric constant of 10 as compared with a dielectric constant of approximately 3 for other commonly used dielectrics. This higher dielectric constant and acceptable dielectric strength results in a relative energy density almost 2 times that of other dielectric systems. This film has been successfully used in portable medical equipment and spacecraft applications where improved energy density is of paramount importance.

PEN has better high temperature resistance, higher mechanical strength, and improved dimensional and chemical stability when compared to polyethylene terephthalate (PET). As a result it is possible to produce PEN in thicknesses below 1.0 $\mu$ m while retaining good handling characteristics. The use of these sub-micron thicknesses gives PEN a significant advantage where high capacitance density is required at relatively low voltages.

FPE has an operating temperature of up to 300°C and is one of the films that is part of the continuous research of very high temperature films Dearborn participates in.

**Metal-Case  
High Temperature  
Metalized Monolithic Polymer  
Capacitors**

**Features—**

- **High Stability**
- **High Insulation Resistance**
- **Low Losses**
- **Low Dielectric Absorption**
- **Hermetically Sealed**

**Major Applications:**

Polycarbonate replacement in timing, and integrating circuitry, high frequency coupling, and other applications where severe environments require hermetically sealed cases

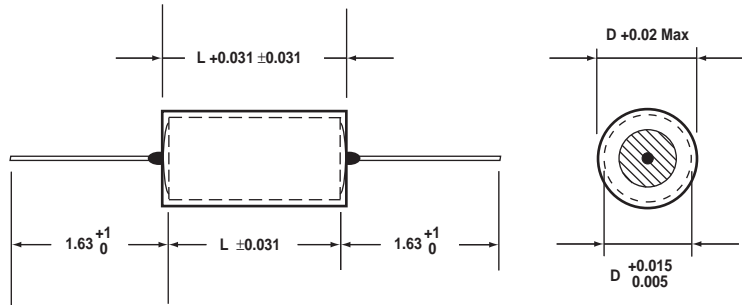

**PHYSICAL CHARACTERISTICS —**

**Construction:**

Non-inductive wound metalized monolithic polymer

**Case:**

Hermetically sealed metal enclosure with insulating sleeve

**Lead Material:**

Solder coated solid wire

**Lead Wire Sizes:**

Case Dia.	Lead AWG
0.195	No. 24
0.235	No. 22
0.312 - 0.400	No. 20
0.500 and over	No. 18

**Lead Pull:**

5 lbs. (2.3 KG) for one minute; no physical damage

**Lead Bend:**

After three complete consecutive bends; no damage

**Marking:**

Dearborn trademark, type or catalog number, capacitance, tolerance and voltage

**ELECTRICAL SPECIFICATIONS —**

**Operating Temperature:**

-65°C to +125°C

**Capacitance Range:**

0.01µF to 20µF

**Capacitance Tolerance:**

±20%, ±10%, ±5%

**Dissipation Factor:**

0.15% maximum @ 1kHz

**Voltage Rating:**

400 VDC to 1200 VDC

**DC Voltage Test:**

150% of rated voltage for 2 minutes

**Insulation Resistance:**

Measured at rated VDC or 500V whichever is less following a 2 minute charge

**At +25°C,** 100,000 Megohm-Microfarads, need not exceed 200,000 Megohms

**At +125°C,** 1,000 Megohm-Microfarads, need not exceed 2,000 Megohms

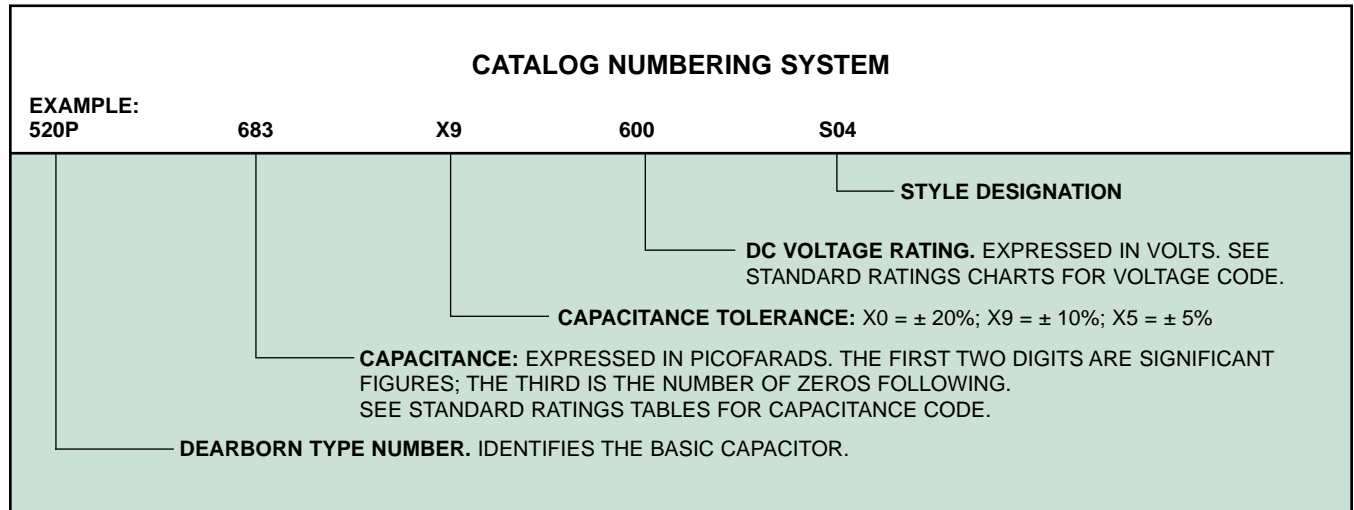

## STANDARD RATINGS

Capacitance μF		Voltage Code 400 400 VDC		Voltage Code 600 600VDC		Voltage Code 800 800VDC		Voltage Code 1K2 1200 VDC	
Code		D	L	D	L	D	L	D	L
0.010	103	0.193	0.813	0.193	0.813	0.193	0.813	-	-
0.022	223	0.193	0.813	0.193	0.813	0.235	1.375	0.235	1.375
0.027	273	0.193	0.813	0.193	0.813	0.235	1.375	0.235	1.375
0.033	333	0.235	0.813	0.235	0.813	0.312	1.375	0.312	1.375
0.039	393	0.235	0.813	0.235	0.813	0.312	0.813	0.312	1.375
0.047	473	0.235	0.813	0.312	0.813	0.312	0.813	0.312	1.375
0.056	563	0.312	0.813	0.312	1.375	0.312	1.375	0.312	1.375
0.068	683	0.193	0.813	0.312	1.375	0.312	1.375	0.312	1.375
0.082	823	0.235	0.813	0.312	0.813	0.235	1.375	0.400	1.375
0.100	104	0.312	0.813	0.312	0.813	0.312	1.375	0.400	1.375
0.120	124	0.400	0.813	0.400	0.813	0.312	1.375	0.400	1.375
0.150	154	0.312	1.375	0.312	1.375	0.312	1.375	0.500	1.375
0.180	184	0.400	1.375	0.400	1.375	0.400	1.375	0.500	1.375
0.220	224	0.312	1.375	0.312	1.375	0.400	1.375	0.562	1.375
0.270	274	0.312	1.375	0.312	1.375	0.400	1.375	0.500	1.875
0.330	334	0.312	1.375	0.312	1.375	0.500	1.375	0.500	1.375
0.390	394	0.312	1.375	0.500	1.375	0.562	1.875	0.562	1.875
0.470	474	0.312	1.375	0.500	1.375	0.500	1.375	0.670	1.875
0.560	564	0.312	1.375	0.400	1.375	0.670	1.875	0.670	1.875
0.680	684	0.312	1.375	0.500	1.375	0.500	1.875	0.670	1.875
0.820	824	0.400	1.375	0.500	1.375	0.750	1.875	0.750	1.875
1.000	105	0.562	1.375	0.562	1.375	0.562	1.875	0.750	2.375
2.000	205	0.500	1.375	1.000	1.875	1.000	1.875	1.000	2.375
3.000	305	0.500	1.875	0.750	1.875	1.000	2.375	-	-
5.000	505	0.750	1.375	1.000	2.375	1.000	2.375	-	-
8.000	805	0.750	1.875	1.000	2.375	-	-	-	-
10.000	106	1.000	1.875	-	-	-	-	-	-
20.000	206	1.000	2.375	-	-	-	-	-	-

Additional capacitance values, voltages, and tolerances are available upon request.

## MPF PERFORMANCE CHARACTERISTICS TYPICAL VALUES COMPARED TO PC AND PPS

$\Delta$ Cap with Temperature(%)

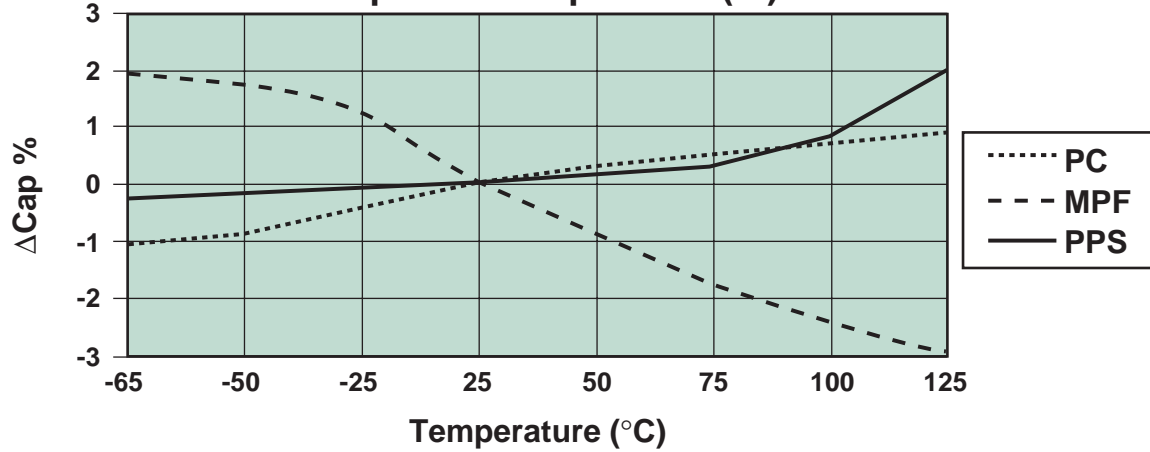

DF vs. Temperature

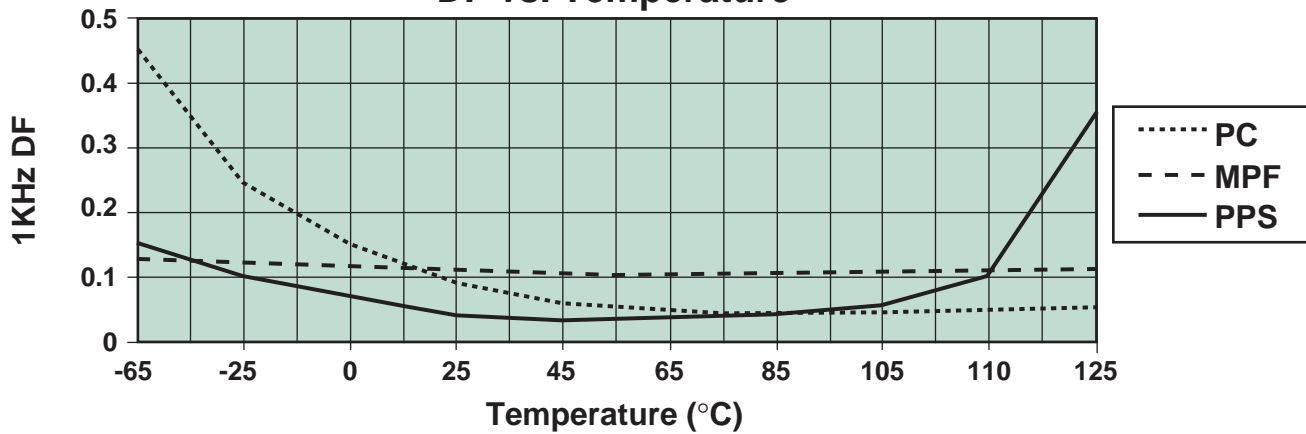

IR vs. Temperature

