

# PAPER/POLYESTER CAPACITORS



<b>Metalized Paper/Polyester Film Capacitors</b>	
Type 118P.....	H-3
<b>Paper Foil Capacitors</b>	
Type 103P.....	H-6
<b>Paper/Polyester Foil Capacitors</b>	
Type 131P.....	H-8
Type 132P.....	H-10
Type CP53/54/55 .....	H-12
<b>High Voltage Paper/Polyester Foil Capacitors</b>	
Type 205P.....	H-15
Type CQ72.....	H-17

## General Electrical, Physical, and Environmental Characteristics

*See the Individual Specification Sheet for Applicable MIL-SPEC*

### Test Procedures:

The test procedures are covered in the applicable MIL spec.

### Electrical Characteristics:

Capacitance, Dissipation Factor, Insulation Resistance, and Dielectric Strength shall be measured as specified in the applicable MIL spec.

### Physical Characteristics:

The terminal strength shall be tested as specified in the applicable MIL spec.

### Environmental Characteristics:

#### Vibration Test: (Per the applicable MIL-SPEC)

No mechanical damage, short, open or intermittent circuit.

#### Moisture Resistance:

The units shall be tested in accordance with the applicable MIL specification.

#### Life:

The units shall be tested in accordance with the applicable MIL specification.

**Metal-Case  
Metalized  
Paper/Polyester  
Capacitors**

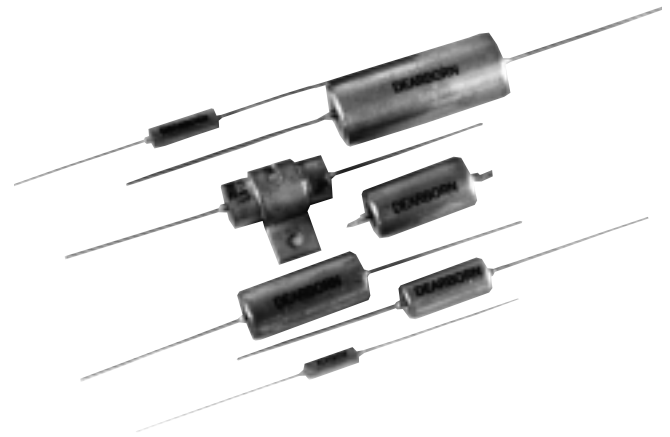

**Features —**

- Moderate Cost
- Small Size
- Extensive Standard Ratings
- Wire Leads or Tab Terminals
- Approved to  
Mil-C-39022/01/02/08

**Major Applications:**

Bypass, coupling, and filtering

**PHYSICAL CHARACTERISTICS —**

**Construction:**

Non-inductive wound metalized paper/polyester

**Case:**

Hermetically sealed metal enclosure. Styles available are shown in picture to the right and in the general section in the front of the catalog

**Lead Material:**

Solder coated solid wire

**Lead Wire Sizes:**

Case Dia.	Lead AWG
0.175 and 0.195	No. 24
0.235 and 0.312	No. 22
0.400 and over	No. 20

**Lead Pull:**

5 lbs. (2.3 KG) for one minute; no physical damage

**Lead Bend:**

After three complete consecutive bends; no damage

**Marking:**

Dearborn trademark, type or catalog number, capacitance, tolerance, and voltage

**ELECTRICAL SPECIFICATIONS —**

**Capacitance Range:**

0.001 $\mu$ F to 12 $\mu$ F

**DC Voltage Rating:**

200 VDC to 1000 VDC

**AC Voltage Rating:**

See graphs of AC voltage vs frequency and AC voltage vs temperature

**Capacitance Tolerance:**

$\pm$ 20%,  $\pm$ 10%,  $\pm$ 5%

**Operating Temperature:**

-55°C to +125°C

**Voltage Derating:**

At +125°C, 50% of +85°C rating

**Dissipation Factor:**

1.0% maximum

**DC Voltage Test:**

200% of rated voltage for 1 minute

**Insulation Resistance:**

Measurements made after a 2 minute charge at rated voltage or 500 VDC, whichever is less

At +25°C, 2,000 Megohm-Microfarads, need not exceed 12,000 Megohms

At +125°C, 40 Megohm-Microfarads, need not exceed 600 Megohms

**STANDARD RATINGS**

Capacitance		Voltage Code 200 200 VDC		Voltage Code 400 400 VDC		Voltage Code 600 600 VDC		Voltage Code 1K0 1000 VDC	
$\mu$ F	Code	D	L	D	L	D	L	D	L
0.0010	102	.174	.750	.235	.750	.235	.750	.400	.750
0.0015	152	.174	.750	.235	.750	.235	.750	.400	.750
0.0022	222	.174	.750	.235	.750	.235	.750	.400	.750
0.0033	332	.174	.750	.235	.750	.235	.750	.400	.750
0.0047	472	.174	.750	.312	.875	.312	.875	.400	.750
0.0068	682	.174	.750	.312	.875	.312	.875	.400	.750
0.010	103	.174	.750	.312	.875	.312	.875	.400	.875
0.015	153	.193	.750	.312	.875	.312	.875	.400	.875
0.022	223	.235	.750	.312	.875	.312	1.125	.400	1.125
0.033	333	.235	.750	.312	1.125	.312	1.125	.400	1.125
0.047	473	.312	.875	.400	1.125	.400	1.125	.500	1.125
0.068	683	.312	.875	.400	1.125	.400	1.125	.500	1.125
0.10	104	.312	.875	.500	1.125	.500	1.125	.562	1.125
0.15	154	.312	1.125	.500	1.125	.562	1.125	.562	1.625
0.22	224	.400	.875	.562	1.375	.562	1.375	.670	1.625
0.33	334	.400	1.125	.562	1.625	.562	1.625	.670	1.875
0.47	474	.500	1.125	.670	1.625	.670	1.625	.750	1.875
0.68	684	.500	1.125	.670	1.875	.670	1.875	1.000	1.875
1.00	105	.562	1.125	.750	1.875	1.000	1.875	1.000	2.125
1.50	155	.562	1.625	1.000	1.875	1.000	1.875	1.000	2.625
2.00	205	.670	1.625	1.000	1.875	1.000	2.125	-	-
3.00	305	.670	1.875	1.000	2.625	-	-	-	-
4.00	405	.750	1.875	-	-	-	-	-	-
5.00	505	1.000	1.875	-	-	-	-	-	-
6.00	605	1.000	1.875	-	-	-	-	-	-
8.00	805	1.000	1.875	-	-	-	-	-	-
10.00	106	1.000	2.375	-	-	-	-	-	-
12.00	126	1.000	2.625	-	-	-	-	-	-

Additional capacitance values, voltages and tolerances available upon request.

**ELECTRICAL CHARACTERISTICS VS TEMPERATURE**

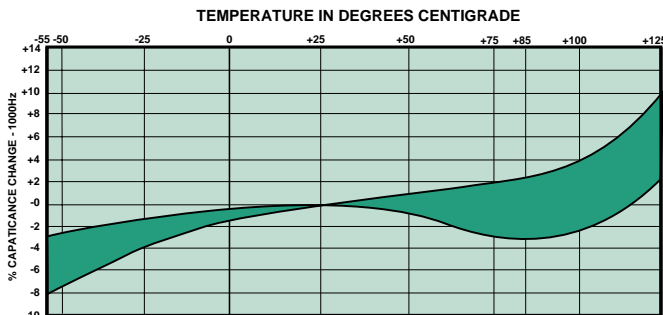

CAPACITANCE CHANGE ENVELOPE FOR 95% CONFIDENCE LEVEL

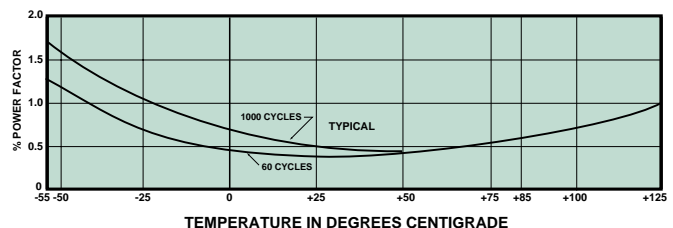

**AC VOLTAGE RATINGS VS TEMPERATURE**

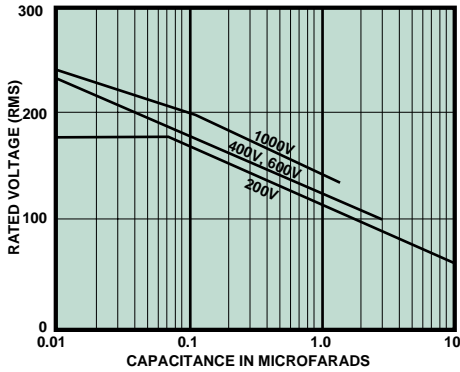

A-C VOLTAGE RATINGS AT 400 HERTZ AND 85 C AMBIENT

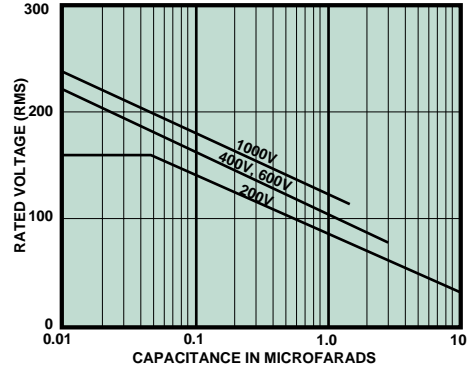

A-C VOLTAGE RATINGS AT 400 HERTZ AND 105 C AMBIENT

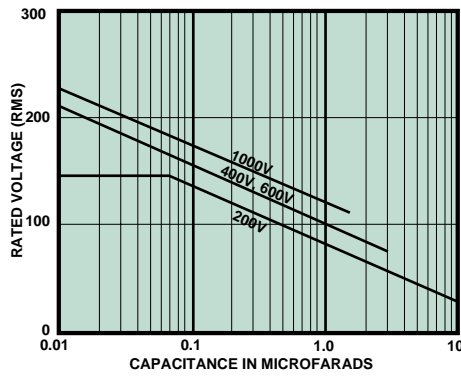

A-C VOLTAGE RATINGS AT 400 HERTZ AND 125 C AMBIENT

**AC VOLTAGE VS FREQUENCY**

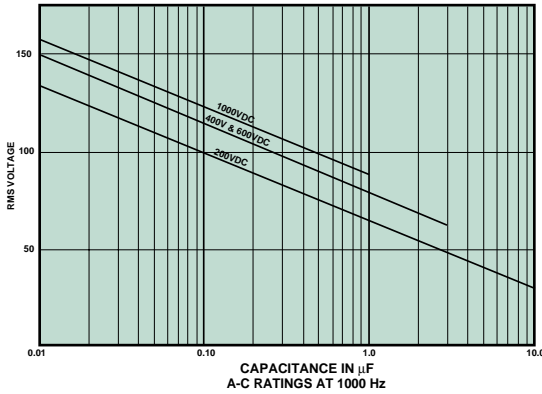

A-C RATINGS AT 1000 Hz

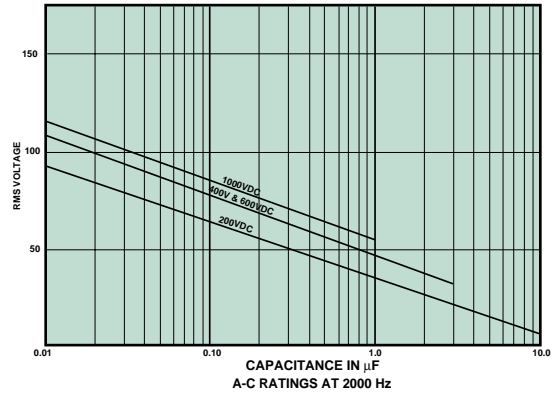

A-C RATINGS AT 2000 Hz

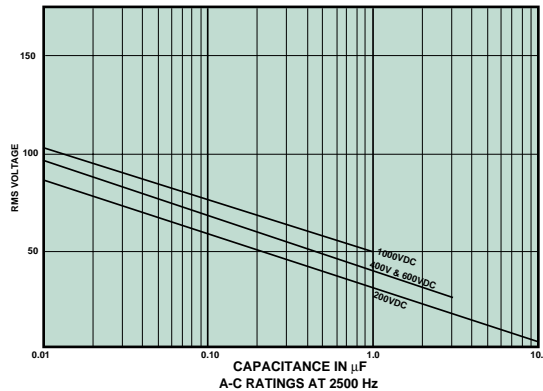

A-C RATINGS AT 2500 Hz

**Metal-Case  
Subminiature  
10 Ampere  
Thru-Pass  
Paper Capacitors**

**TYPE 103P**

**Features —**

- Bulkhead Mounting
- Excellent RFI Specs
- Hermetically Encased
- Low Inductance Connection
- Low Insertion Loss
- Approved to Mil-C-11693/07
- 10 Amp Current Ratings

**Major Applications:**

Used to suppress RF interference in the following equipment, rotating machinery, ignition systems, electromechanical devices, and electronic devices

**PHYSICAL CHARACTERISTICS —**

**Construction:**

Non-inductive wound paper/foil, wound around a feed-thru bus. The case is the common ground of the three terminal network

**Case:**

Hermetically sealed metal enclosure; the case and terminal styles are shown above

**Lead Pull:**

5 lbs. (2.3 KG) for one minute; no physical damage

**Lead/Bend:**

After three complete consecutive bends; no damage

**Marking:**

Dearborn trademark, type or catalog number, capacitance, tolerance and voltage

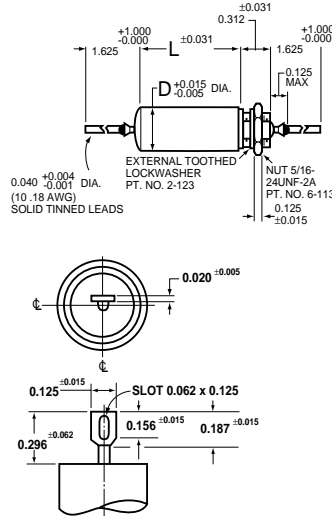

**CIRCUIT DIAGRAM**

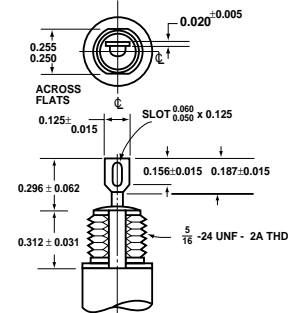

**ELECTRICAL SPECIFICATIONS —**

**Capacitance Range:**

0.001μF to 1.0μF

**DC Voltage Range:**

200 VDC to 600 VDC

**Capacitance Tolerance:**

±20%, ±10%

**Operating Temperature:**

-55°C to +125°C

**Voltage Derating:**

At +125°C, 50% of the 85°C rating

**Dissipation Factor:**

1.0% maximum

**Voltage Test:**

200% of rated voltage for 2 minutes

**Insulation Resistance:**

Measure at rated voltage, not to exceed 500 VDC, after a 2 minute charge

At +25°C, 20,000 Megohm-Microfarads, need not exceed 30,000 Megohms

At +85°C, 200 Megohm-Microfarads, need not exceed 300 Megohms

**DC Resistance:**

0.01 ohms maximum

**Insertion Loss:**

(see table on next page)

**ELECTRICAL CHARACTERISTICS VS TEMPERATURE**

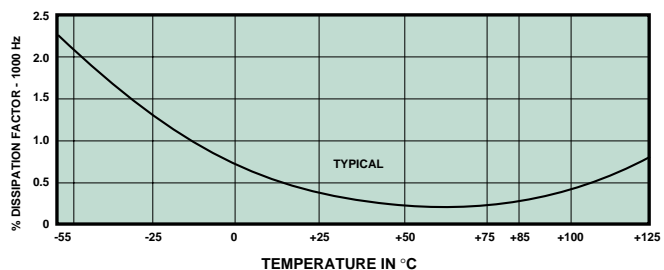
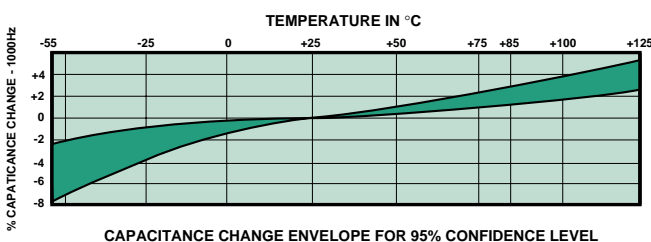

**STANDARD RATINGS**

μF	Catalog No. *		Inches		Millimeters	
	Tab.Term	Wire Lead	D	L	D	L
<b>200 VOLTS DC</b>						
0.047	103P473X0200T	103P473X0200S	.400	.875	10.16	22.23
0.10	103P104X0200T	103P104X0200S	.400	1.125	10.16	28.58
0.22	103P224X0200T	103P224X0200S	.562	1.125	14.27	28.58
0.47	103P474X0200T	103P474X0200S	.562	1.875	14.27	47.53
1.00	103P105X0200T	103P105X0200S	.750	2.125	19.05	53.96
<b>300 VOLTS DC</b>						
0.047	103P473X0300T	103P473X0300S	.400	1.125	10.16	28.58
0.10	103P104X0300T	103P104X0300S	.400	1.375	10.16	34.83
0.22	103P224X0300T	103P224X0300S	.562	1.375	14.27	34.83
0.47	103P474X0300T	103P474X0300S	.670	1.875	17.02	47.83
<b>400 VOLTS DC</b>						
0.047	103P473X0400T	103P473X0400S	.400	1.375	10.16	34.93
0.10	103P104X0400T	103P104X0400S	.562	1.125	14.27	28.58
0.22	103P224X0400T	103P224X0400S	.562	1.875	14.27	47.83
0.47	103P474X0400T	103P474X0400S	.750	2.125	19.05	53.98
<b>600 VOLTS DC</b>						
0.0010	103P102X0600T	103P102X0600S	.400	.750	10.16	19.05
0.0047	103P472X0600T	103P472X0600S	.400	.750	10.16	19.05
0.010	103P103X0600T	103P103X0600S	.400	.750	10.16	19.05
0.047	103P473X0600T	103P473X0600S	.400	1.375	10.16	34.93
0.10	103P104X0600T	103P104X0600S	.562	1.375	14.27	34.93
0.22	103P224X0600T	103P224X0600S	.670	1.875	17.02	47.83
0.47	103P474X0600T	103P474X0600S	.750	2.375	19.05	60.32

\*The catalog numbers given are for capacitance tolerance of ± 20%. To specify ± 10% tolerance, change X0 to X9. Mounting hardware furnished unassembled.

**Insertion Loss Characteristics for Ideal Capacitors**

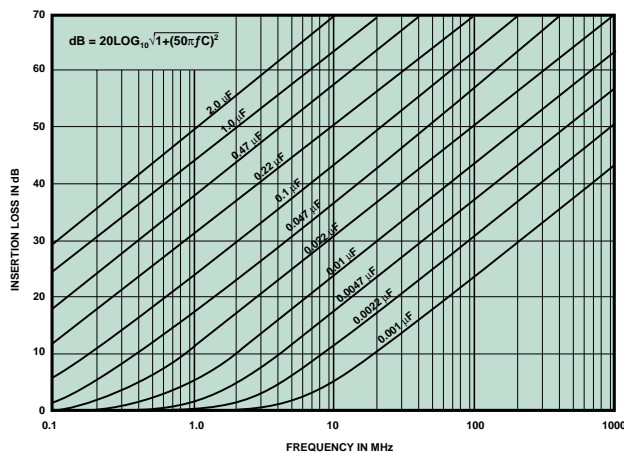

These capacitors are designed to meet all the electrical, mechanical, and environmental requirements of Military Specification MIL-C-11693. The insertion loss of such capacitors is defined by this military specification as follows. "...the insertion loss shall be not more than 6 decibels (dB) permissible dips below the value shown on the graph above for an ideal capacitor of the same nominal capacitance value, when tested at frequencies from 0.15 megahertz (MHz) up to that frequency at which the insertion loss of the capacitor under test becomes 60 dB; at all higher frequencies, up to 1000 MHz, the insertion loss shall not fall below 60 dB. Deviations in the nature of dips in the curve will be permitted; such dips indicate a drop in insertion loss below that of an ideal capacitor followed by a rise in insertion loss, as frequency is increased, faster than the rise that is characteristic of an ideal capacitor. Such dips are characteristic of all extended foil capacitors."

**Metal-Case  
Paper/Polyester Dielectric  
Extended Foil Electrodes**

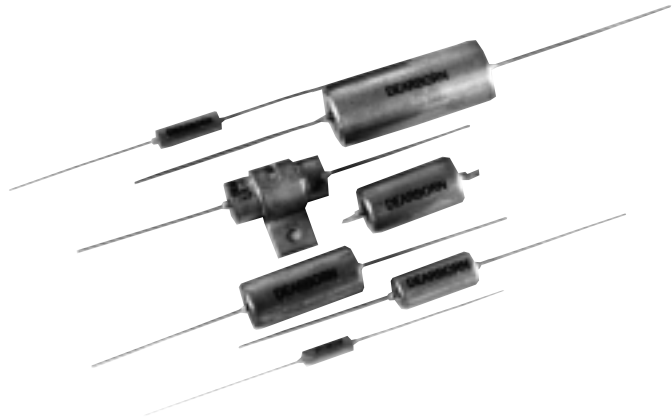

**Features —**

- Moderate Cost
- Small Size
- High Peak Current Ratings
- High Corona Starting Voltage
- Approved to Mil-C-19978

**Major Applications:**

High voltage, high current, high pulse operations, protection circuits, and snubber applications

**PHYSICAL CHARACTERISTICS —**

**Construction:**

Non-inductive wound paper/polyester dielectric with extended foil electrodes. Impregnated with vitamin Q

**Case:**

Hermetically sealed metal enclosure. Styles available are shown in picture to the right and in the general section in the front of the catalog

**Lead Material:**

Solder coated solid wire

**Lead Wire Sizes:**

Case Dia.	Lead AWG
0.235 and 0.312	No. 22
0.400 and over	No. 20

**Lead Pull:**

5 lbs. (2.3 KG) for one minute; no physical damage

**Lead Bend:**

After three complete consecutive bends; no damage

**Marking:**

Dearborn trademark, type or catalog number, capacitance, tolerance, and voltage

**ELECTRICAL SPECIFICATIONS —**

**Capacitance Range:**

0.001 $\mu$ F to 1.0 $\mu$ F

**Voltage Rating:**

200 VDC to 1000 VDC

**Capacitance Tolerance:**

$\pm$ 20%,  $\pm$ 10%,  $\pm$ 5%

**Operating Temperature:**

-65°C to +125°C

**Voltage Derating:**

At +125°C, 50% of the 85°C rating

**Dissipation Factor:**

1.0% maximum

**DC Voltage Test:**

200% of rated voltage for 2 minutes

**Insulation Resistance:**

Measure at rated VDC or 500V, whichever is less, after a 2 minute charge

At +25°C, 20,000 Megohm-Microfarads, need not exceed 30,000 Megohms

At +125°C, 20 Megohm-Microfarads, need not exceed 250 Megohms

**MAXIMUM PULSE RISE TIME**

Capacitor Length in Inches	Rise Time dv/dt (V/ $\mu$ s)			
	200 VDC	400 VDC	600 VDC	1000 VDC
0.750	1600	1600	4500	-
0.875	1000	1400	1500	2500
1.125	500	800	1000	1500
1.375	350	500	800	1000
1.625	250	350	500	800
1.875	-	-	-	550
2.125	200	300	400	500
2.375	-	-	300	450

## STANDARD RATINGS

Capacitance		Voltage Code 200 200 VDC		Voltage Code 400 400 VDC		Voltage Code 600 600 VDC		Voltage Code 1K0 1000 VDC	
$\mu$ F	Code	D	L	D	L	D	L	D	L
0.0010	102	-	-	-	-	.235	.750	.400	.875
0.0015	152	-	-	-	-	.235	.750	.400	.875
0.0022	222	-	-	-	-	.235	.750	.400	.875
0.0033	332	-	-	.235	.750	.312	.875	.400	.875
0.0047	472	.235	.750	.235	.750	.312	.875	.400	.875
0.0068	682	.235	.750	.235	.750	.312	.875	.400	.875
0.010	103	.235	.750	.235	.750	.312	.875	.400	.875
0.015	153	.312	.875	.312	.875	.400	.875	.400	1.125
0.022	223	.312	.875	.400	.875	.400	.875	.400	1.375
0.033	333	.312	.875	.400	.875	.400	1.125	.562	1.125
0.047	473	.400	.875	.400	1.125	.400	1.375	.562	1.375
0.068	683	.400	.875	.400	1.375	.562	1.125	.562	1.625
0.10	104	.400	1.125	.562	1.125	.562	1.375	.670	1.625
0.15	154	.400	1.375	.562	1.375	.562	1.625	.670	1.875
0.22	224	.562	1.125	.562	1.625	.670	1.625	.750	2.125
0.33	334	.562	1.375	.670	1.625	.750	2.125	1.000	2.125
0.47	474	.562	1.625	.750	2.125	.750	2.375	1.000	2.375
0.68	684	.670	1.625	-	-	-	-	-	-
1.00	105	.750	2.125	-	-	-	-	-	-

Additional capacitance values, voltages, and tolerances are available upon request.

\* The dimensions shown are for style 02. The dimensions for other styles are included in the general section in the front of the catalog.

**Metal-Case  
Paper/Polyester Dielectric  
Extended Foil Electrodes**

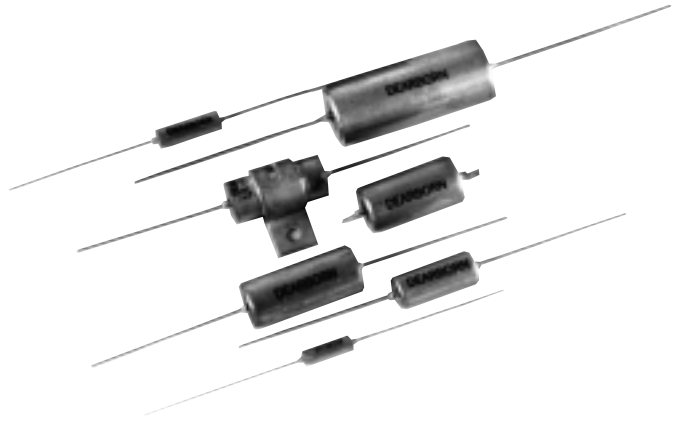

**Features —**

- Moderate Cost
- Small Size
- High Peak Current Ratings
- High Corona Starting Voltage
- Approved to Mil-C-19978

**Major Applications:**

High voltage, high current, high pulse operations, protection circuits, and snubber applications

**PHYSICAL CHARACTERISTICS —**

**Construction:**

Non-inductive wound paper/polyester dielectric with extended foil electrodes. Impregnated with vitamin Q

**Case:**

Hermetically sealed metal enclosure. Styles available are shown in picture to the right and on page 2

**Lead Material:**

Solder coated solid wire

**Lead Wire Sizes:**

Case Dia.	Lead AWG
<0.235	No. 24
<0.235 and .0312	No. 22
0.400 and over	No. 20

**Lead Pull:**

5 lbs. (2.3 KG) for one minute; no physical damage

**Lead Bend:**

After three complete consecutive bends; no damage

**Marking:**

Dearborn trademark, type or catalog number, capacitance, tolerance, and voltage

**ELECTRICAL SPECIFICATIONS —**

**Capacitance Range:**

0.001 $\mu$ F to 1.0 $\mu$ F

**Voltage Rating:**

100 VDC to 1000 VDC

**Capacitance Tolerance:**

$\pm$ 20%,  $\pm$ 10%,  $\pm$ 5%

**Operating Temperature:**

-65°C to +125°C

**Voltage Derating:**

At +125°C, 50% of the 85°C rating

**Dissipation Factor:**

1.0% maximum

**DC Voltage Test:**

200% of rated voltage for 2 minutes

**Insulation Resistance:**

Measure at rated VDC or 500V, whichever is less, after a 2 minute charge

At +25°C, 20,000 Megohm-Microfarads, need not exceed 30,000 Megohms

At +125°C, 20 Megohm-Microfarads, need not exceed 250 Megohms

**MAXIMUM PULSE RISE TIME**

Capacitor Length in Inches	Rise Time dv/dt (V/ $\mu$ s)					
	100 VDC	200 VDC	300 VDC	400 VDC	600 VDC	1000 VDC
0.687/0.750	800	1600	2000	3000	4500	-
0.812/0.875	700	1000	1000	1000	1500	2500
1.062/1.125	400	500	650	800	1000	1500
1.312/1.375	300	350	425	500	800	1000
1.562/1.625	200	250	300	350	500	800
1.812/1.875	-	-	-	-	-	550
2.062/2.125	-	200	250	300	400	500
2.312/2.375	-	-	-	-	300	450

## STANDARD RATINGS

Capacitance μF		Voltage Code 100 100 VDC		Voltage Code 200 200 VDC		Voltage Code 300 300 VDC	
	Code	D	L	D	L	D	L
0.0010	102	.175	0.687	.235	0.687	.235	0.687
0.0015	152	.175	0.687	.235	0.687	.235	0.687
0.0022	222	.175	0.687	.235	0.687	.235	0.687
0.0033	332	.175	0.687	.235	0.687	.235	0.687
0.0047	472	.175	0.687	.235	0.687	.235	0.687
0.0068	682	.195	0.687	.235	0.687	.312	0.812
0.010	103	.235	0.687	.312	0.812	.312	0.812
0.015	153	.235	0.687	.312	0.812	.312	0.812
0.022	223	.312	0.812	.312	0.812	.312	0.812
0.033	333	.312	0.812	.312	0.812	.400	0.812
0.047	473	.312	0.812	.400	0.812	.400	0.812
0.068	683	.400	0.812	.400	0.812	.400	1.062
0.10	104	.400	0.812	.400	1.062	.400	1.312
0.15	154	.400	1.062	.400	1.312	.562	1.062
0.22	224	.400	1.062	.562	1.062	.562	1.312
0.33	334	.562	1.062	.562	1.312	.562	1.562
0.47	474	.562	1.312	.562	1.562	.670	1.562
0.68	684	.562	1.562	.670	1.562	.750	2.062
1.00	105	.670	1.562	.750	2.062	-	-

Capacitance μF		Voltage Code 400 400 VDC		Voltage Code 600 600 VDC		Voltage Code 1K0 1000 VDC	
	Code	D	L*	D	L*	D	L*
0.0010	102	.235	0.687	.235	0.687	.400	0.812
0.0015	152	.235	0.687	.235	0.687	.400	0.812
0.0022	222	.235	0.687	.235	0.687	.400	0.812
0.0033	332	.235	0.687	.312	0.812	.400	0.812
0.0047	472	.312	0.812	.312	0.812	.400	0.812
0.0068	682	.195	0.812	.312	0.812	.400	0.812
0.010	103	.312	0.812	.312	0.812	.400	0.812
0.015	153	.312	0.812	.400	0.812	.400	1.062
0.022	223	.400	0.812	.400	0.812	.400	1.312
0.033	333	.400	0.812	.400	1.062	.562	1.062
0.047	473	.400	1.062	.400	1.312	.562	1.312
0.068	683	.400	1.312	.562	1.062	.562	1.562
0.10	104	.562	1.062	.562	1.312	.670	1.562
0.15	154	.562	1.312	.562	1.562	.670	1.812
0.22	224	.562	1.562	.670	1.562	.750	2.062
0.33	334	.670	1.562	.750	2.062	1.000	2.062
0.47	474	.750	2.062	.750	2.312	1.000	2.312

Additional capacitance values, voltages, and tolerances are available upon request.

\* The dimensions Tabulated above are for styles 01, 03, and 12. Add 0.062" to the length for styles 02, 04, and 13.



**Bathtub Style  
Metal Case  
Paper/Polyester  
Foil Capacitors**

**Features —**

- Capacitance Values to 10μF
- Drawn Metal “Bathtub” Cases
- Top, Side, or Bottom Terminals
- Approved to MIL-C-25

**Major Applications:**

Bypass, coupling, filtering

**PHYSICAL CHARACTERISTICS —**

**Construction:**

Non-inductive wound paper/polyester film with extended foil electrodes

**Case:**

Hermetically sealed metal enclosure. Styles available are shown in drawing above

**Terminals: Symbol B**

Glass to metal solder-seal with non removable solder lug

**Marking:**

Dearborn trademark, type number, capacitance, tolerance, voltage, and date code

**ELECTRICAL SPECIFICATIONS —**

**Capacitance Range:**

0.05μF to 10.0μF

**DC Voltage Rating:**

100 VDC to 1,000 VDC

**Capacitance Tolerance:**

K, ±10%; V, +20 -10%

**Operating Temperature:**

Characteristics E and F -55°C to +85°C

Characteristic K -55°C to +125°C

**Voltage Derating:**

Characteristics E and F at +85°C, 65% of rated voltage

Characteristic K at +125°C, 70% of rated voltage

**Dissipation Factor:**

1.0% maximum

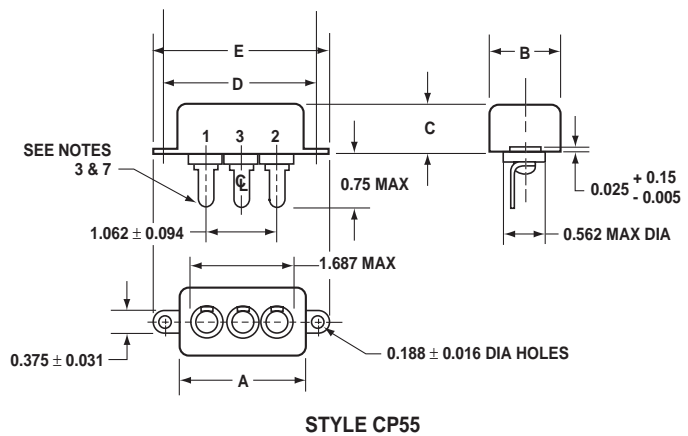
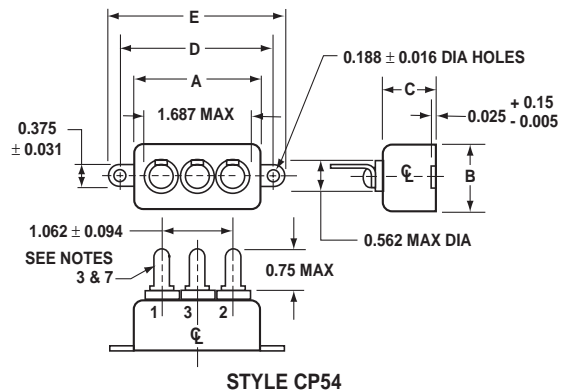
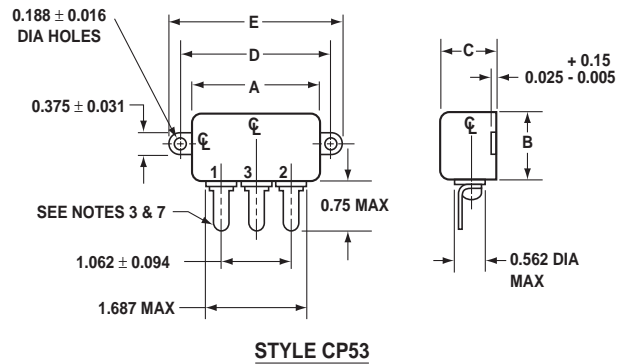

**Notes:**

1. See following tables for additional dimensions.
2. All dimensions in inches
3. Terminals need not be identified by numbers as shown. Shape of terminals and terminal lugs (drilled, punched, forked, or slotted) optional.
4. Mounting holes may be elongated.
5. For circuit 1, use terminals 1 and 2. For circuit 2, use terminal 1. For circuit 4, use terminal 1 for common connection and identify common terminal by the letter C on case adjacent to terminal. For circuit 6, use terminals 1 and 2.
6. Capacitors differ only in location of terminals. Style CP53, having the terminals on one side, contains certain values of capacitance in a smaller case than is possible with styles CP54 and CP55, the terminals of which are on top and bottom faces respectively.
7. Terminal lugs shall be oriented as shown with respect to side of case bearing terminal identification numbers.

**DIELECTRIC WITHSTANDING VOLTAGE TEST**

Circuit Symbol	Circuit Diagram	Test	Test Connections	Test Voltage (Percent of Rated DC Voltage)	Time Test Applied (minutes)
1		Terminal to terminal	1 to 2	200 <sup>1/</sup>	1 <sup>2/</sup>
		Terminal to case	1 and 2 to case	400 <sup>5/</sup> 200 + 1,000 <sup>6/</sup> volts	1 <sup>3/ 4/</sup> 1 <sup>3/ 4/</sup>
2		Terminal to terminal	1 to case	200 <sup>1/</sup>	1 <sup>2/</sup>
4		Terminal to terminal	1 to 2 and 3 together	200 <sup>1/</sup>	1 <sup>7/</sup>
		Terminal to case	1, 2, and 3 to case	400	1 <sup>3/ 4/</sup>
				200 + 1,000 volts	1 <sup>3/ 4/</sup>
5		Terminal to case	1, 2, and 3 to case	200	1 <sup>7/</sup>
		Terminal to terminal	1 and 2 to 3	200	1 <sup>7/</sup>
				200	1 <sup>7/</sup>
6		Terminal to terminal	1 and 2 to case	200	1 <sup>7/</sup>
			1 to 2	200	1 <sup>7/</sup>

<sup>1/</sup> 175 percent of rated dc voltage after temperature-and immersion-cycling and moisture resistance tests.

<sup>2/</sup> For quality conformance inspection and at the option of the supplier, either 200 percent of rated dc voltage for not less than 15 seconds or 250 percent of rated voltage for not less than 1 second.

<sup>3/</sup> For quality conformance inspection, the period of test voltage application shall be 1 second.

<sup>4/</sup> For quality conformance inspection, applications may be made between each terminal individually and the case, at the option of the supplier.

<sup>5/</sup> For capacitors having dc voltage ratings of 600 volts and less.

<sup>6/</sup> For capacitors having dc voltage ratings greater than 600 volts.

<sup>7/</sup> For quality conformance inspection, the application may be made for 1 second if the capacitor has passed group A inspection.

**TERMINAL TO TERMINAL INSULATION RESISTANCE MEASUREMENTS**

Capacitance values	Minimum insulation resistance <sup>1/</sup>		
	Characteristic E	Characteristic F	Characteristic K
0.33 microfarads and less greater than 0.33 microfarads	At 25°C 6,000 megohms 2,000 megohm-microfarads <sup>2/</sup>	At 25°C 4,500 megohms 1,500 megohm-microfarads <sup>2/</sup>	At 25°C 18,000 megohms 6,000 megohm-microfarads <sup>2/</sup>
greater than 0.033 microfarads	At 85°C 20 megohm-microfarads <sup>2/</sup>	At 85°C 15 megohm-microfarads <sup>2/</sup>	- - -
0.067 microfarads and less Greater than 0.67 microfarads	- - -	- - -	At 125°C 150 megohms 10 megohm-microfarads <sup>2/</sup>

<sup>1/</sup> A potential equal to the dc rated voltage or 500 volts dc, whichever is less shall be applied.

<sup>2/</sup> Product obtained by multiplying the capacitance in microfarads by the insulation resistance in megohms.

STYLES CP53, CP54 AND CP55 CHARACTERISTICS AND DIMENSIONS

Type designation <sup>1/</sup>	De voltage Rating (see fig. 2)	Capacitance $\mu$ F	Capacitance Tolerance <sup>2/</sup>	Charac-teristics	Vibration Grade	Case Size		
						Charac-teristic E	Charac-teristic F	Charac-teristic K
CP5-B---B105K1	100	1	K	E, F	1	A2	A1	-
CP5-B-EB205K1	100	2	K	E	1	B1	-	-
CP5-B---B405K1	100	4	K	E, F	1	C2	C1	-
CP5-B-FB805K1	100	8	K	F	1	-	C1	-
CP5-B-FB106K1	100	10	K	F	1	-	C2	-
CP5-B-FC504K1	200	0.5	K	F	1	-	A1	-
CP5-B-EC105K1	200	1	K	E	1	B1	-	-
CP5-B-EC205K1	200	2	K	E	1	C1	-	-
CP5-B-KE503K1	400	0.05	K	K	1	-	-	A1
CP5-B-KE104K1	400	0.10	K	K	1	-	-	A1
CP5-B-KE254K1	400	0.25	K	K	1	-	-	A1
CP5-B-KE504K1	400	0.5	K	K	1	-	-	B1
CP5-B-KE105K1	400	1	K	K	1	-	-	B1
CP5-B-EF254K1	600	0.25	K	E	1	A1	-	-
CP5-B---F504K1	600	0.5	K	E, F	1	A3	A2	-
CP5-B---F105K1	600	1	K	E, F	1	B2	B1	-
CP5-B-EF205K1	600	2	K	E	1	C2 <sup>3/</sup>	-	-
CP5-B-EG503K1	1,000	0.05	K	E	1	A1	-	-
CP5-B-EG104K1	1,000	0.1	K	E	1	A1	-	-
CP5-B---G254K1	1,000	0.25	K	E, F	1	A2	A1	-
CP5-B-EG504K1	1,000	0.5	K	E	1	B1	-	-
CP5-B-EG105K1	1,000	1	K	E	1	C2 <sup>3/</sup>	-	-
CP5-B-EF503V1	600	0.05-0.05 <sup>4/</sup>	V	E	1	A1	-	-
CP5-B-EF104V1	600	0.1-0.1	V	E	1	A1	-	-
CP5-B---F254V1	600	0.25-0.25	V	E, F	1	A3	A2	-
CP5-B---F504V1	600	0.5-0.5	V	E, F	1	B2	B1	-
CP5-B-EF105V1	600	1-1	V	E	1	C2 <sup>3/</sup>	-	-
CP5-B-EG503V1	1,000	0.05-0.05	V	E	1	A1	-	-
CP5-B---G104V1	1,000	0.1-0.1	V	E, F	1	A2	A1	-
CP5-B-EG254V1	1,000	0.25-0.25	V	E	1	B1	-	-
CP5-B-EG504V1	1,000	0.5-0.5	V	E	1	C2 <sup>3/</sup>	-	-
CP5-B5--E504V1	400	0.5-0.5-0.5	V	E, F	1	C2	C1	-
CP5-B5--F104V1	600	0.1-0.1-0.1	V	E, F	1	A2	A1	-
CP5-B5EF254V1	600	0.25-0.25-0.25	V	E	1	B1	-	-
CP5-B5EF504V1	600	0.5-0.5-0.5	V	E	1	C2 <sup>3/</sup>	-	-
CP5-B5EG503V1	1,000	0.05-0.05-0.05	V	E	1	A1	-	-
CP5-B5EG104V1	1,000	0.1-0.1-0.1	V	E	1	B1	-	-
CP5-B5EG254V1	1,000	0.25-0.25-0.25	V	E	!	C2 <sup>3/</sup>	-	-

<sup>1/</sup> Complete type designation shall include additional symbols to complete style designation. Indicate circuit (where applicable) and characteristics (where applicable).

<sup>2/</sup> Capacitance tolerance in percent: K,  $\pm$ 10; V, +20, -10.

<sup>3/</sup> For styles CP54 and CP55, case size is C3.

<sup>4/</sup> For multiple-unit capacitors, the watt-second rating is the sum of the watt-second ratings of the component sections.

CASE DIMENSIONS

Case Size	Dimensions				
	A $\pm$ 0.062	B $\pm$ 0.062	+0.062 C -0.125	D $\pm$ 0.031	E $\pm$ 0.062
A1	1.812	1.000	0.750	2.125	2.500
A2	1.812	1.000	0.875	2.125	2.500
A3	1.812	1.000	1.000	2.125	2.500
B1	2.000	1.750	0.875	2.375	2.750
B2	2.000	1.750	1.000	2.375	2.750
C1	2.000	2.000	1.000	2.375	2.750
C2	2.000	2.000	1.125	2.375	2.750
C3	2.000	2.000	1.250	2.375	2.750

Refer to Mil-C-25/4 for additional information.

**Glass Tubular  
High-Voltage  
Paper/Polyester  
Difilm® Capacitors**

**Features —**

- Glass Case
- 2000 VDC To 10,000 VDC
- Two Temperature Ranges
- Long Leakage Path
- High Altitude Stability
- Similar Parts Approved to Mil-C-19978/02

**Major Applications:**

High voltage applications both at high altitude, and ground level. Power supplies, induction heating equipment, electrostatic precipitators, as well as coupling and bypass applications

**PHYSICAL CHARACTERISTICS —**

**Construction:**

Dielectric-paper/polyester, electrode-aluminum foil either extended or laid in tab. Impregnated with vitamin Q

**Case:**

Heavy wall tempered glass. Metal ferrules are bonded to the end of the glass and metal end caps are soldered to the ferrules to make a hermetically sealed assembly

**Lead/Terminals:**

Tubes with a diameter of 0.53 inches have 20 AWG leads. Larger tube diameters have 8-32 studs on both ends

**Lead Pull:**

5 lbs. (2.3 KG) for one minute; no physical damage

**Marking:**

Dearborn trademark, type or catalog number, capacitance, and voltage

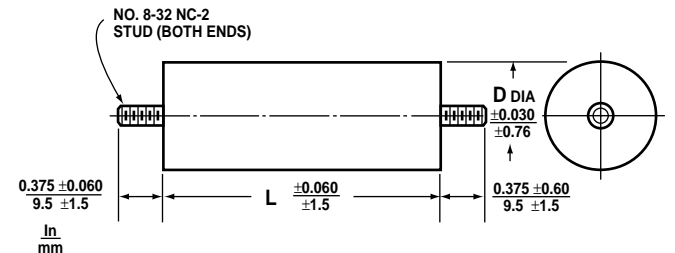
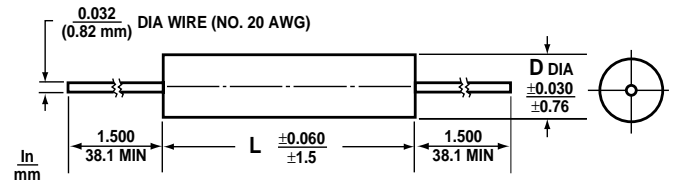

**ELECTRICAL SPECIFICATIONS —**

**Capacitance Range:**

0.001µF to 0.5µF

**Voltage Rating:**

2,000 VDC to 10,000 VDC

**Capacitance Tolerance:**

±20%, ±10%

**Operating Temperature:**

-55°C to +85°C or  
-55°C to +125°C

**Dissipation Factor:**

1.0% maximum

**DC Voltage Test:**

175% of rated voltage for 1 minute

**Insulation Resistance:**

Measure at 500 VDC after a 2 minute charge  
**At +25°C**, 20,000 Megohm-Microfarads, need not exceed 100,000 Megohms  
**At +85°C**, 300 Megohm-Microfarads, need not exceed 2,000 Megohms  
**At +125°C**, 20 Megohm-Microfarads, need not exceed 250 Megohms

**ELECTRICAL CHARACTERISTICS VS TEMPERATURE**

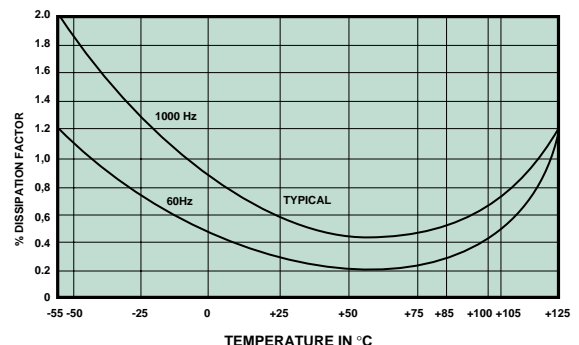
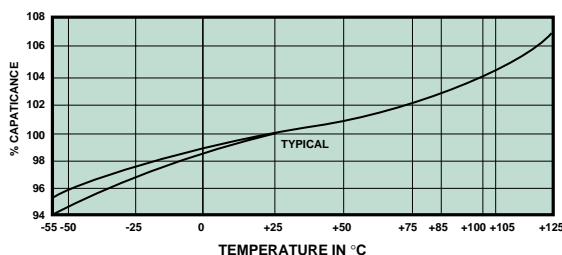

### STANDARD RATINGS

μF	STANDARD RATINGS FOR +85°C OPERATION			STANDARD RATINGS FOR +125°C OPERATION		
	Catalog Number	Inches		Catalog Number	Inches	
		D	L		D	L
<b>2,000 VOLTS DC</b>						
0.001	-	-	-	205P102X92K0SK	0.53	1.19
0.002	-	-	-	205P202X92K0SK	0.53	1.19
0.005	-	-	-	205P502X92K0SK	0.53	1.19
0.01	-	-	-	205P103X92K0SK	0.53	1.19
0.02	205P203X92K0SE	0.53	1.56	205P203X92K0LK	0.63	1.56
0.05	205P503X92K0LE	0.75	1.75	205P503X92K0LK	0.75	2.25
0.10	205P104X92K0LE	0.75	2.25	205P104X92K0LK	1.03	2.25
0.25	205P254X92K0LE	1.03	2.75	205P254X92K0LK	1.34	3.50
0.50	205P504X92K0LE	1.34	2.75	-	-	-
<b>3,000 VOLTS DC</b>						
0.001	-	-	-	205P102X93K0SK	0.53	1.19
0.002	-	-	-	205P202X92K0SK	0.53	1.19
0.005	205P502X92K0SE	0.53	1.19	205P502X92K0SK	0.53	1.56
0.01	205P103X92K0SE	0.53	1.56	205P103X93K0LK	0.63	1.56
0.02	205P203X92K0LE	0.63	2.25	205P203X93K0LK	0.75	1.75
0.05	205P503X92K0LE	0.75	2.25	205P503X93K0LK	1.03	2.25
0.10	205P104X92K0LE	1.03	2.25	205P104X93K0LK	1.34	2.75
0.25	205P254X93K0LE	1.34	2.75	-	-	-
<b>4,000 VOLTS DC</b>						
0.001	205P102X94K0SE	0.53	1.19	205P102X94K0SK	0.53	1.56
0.002	205P202X94K0SE	0.53	1.19	205P202X94K0SK	0.53	1.56
0.005	205P502X94K0SE	0.53	1.56	205P502X94K0LK	0.63	1.56
0.01	205P103X94K0LE	0.63	1.56	205P103X94K0LK	0.75	1.75
0.02	205P203X94K0LE	0.75	1.75	205P203X94K0LK	0.75	2.25
0.05	205P503X94K0LE	0.87	2.25	205P503X94K0LK	1.34	2.75
0.10	205P104X94K0LE	1.03	2.75	205P104X94K0LK	1.34	2.75
0.25	205P254X94K0LE	1.34	3.50	-	-	-
<b>5,000 VOLTS DC</b>						
0.001	-	-	-	205P102X95K0SK	0.53	1.56
0.002	-	-	-	205P202X95K0SK	0.53	1.56
0.005	205P502X95K0SE	0.53	1.56	205P502X95K0LK	0.63	1.56
0.01	205P103X95K0LE	0.63	1.56	205P103X95K0LK	0.75	1.75
0.02	205P203X95K0LE	0.75	1.75	205P203X95K0LK	0.87	2.75
0.05	205P503X95K0LE	0.87	2.25	205P503X95K0LK	1.34	2.25
0.10	205P104X95K0LE	1.03	2.75	205P104X95K0LK	1.34	3.50
<b>7,500 VOLTS DC</b>						
0.001	205P102X97K5LE	0.63	2.25	205P102X97K5LK	0.63	2.25
0.002	205P202X97K5LE	0.63	2.25	205P202X97K5LK	0.75	1.75
0.005	205P502X97K5LE	0.75	1.75	205P502X97K5LK	0.75	2.25
0.01	205P103X97K5LE	0.75	2.25	205P103X97K5LK	0.87	2.25
0.02	205P203X97K5LE	1.03	2.75	205P203X97K5LK	1.34	2.75
0.03	-	-	-	205P303X97K5LK	1.34	2.75
0.05	205P503X97K5LE	1.34	2.75	205P503X97K5LK	1.34	4.25
0.10	205P104X97K5LE	1.34	3.50	-	-	-
<b>10,000 VOLTS DC</b>						
0.0001	-	-	-	205P101X910KLK	0.63	2.25
0.0002	-	-	-	205P201X910KLK	0.63	2.25
0.0005	-	-	-	205P501X910KLK	0.63	2.25
0.001	205P102X910KLE	0.63	2.25	205P102X910KLK	0.75	2.25
0.002	205P202X910KLE	0.63	2.25	205P202X910KLK	0.87	2.25
0.005	205P502X910KLE	0.75	2.25	205P502X910KLK	1.03	2.75
0.01	205P103X910KLE	1.03	2.75	205P103X910KLK	1.34	2.75
0.02	205P203X910KLE	1.34	2.75	205P203X910KLK	1.34	4.25
0.05	205P503X910KLE	1.34	4.25	-	-	-

\*The catalog numbers given are for capacitance tolerance of ± 10%. To specify ± 20% tolerance, change X9 to X0.

**Rectangular  
Metal Case  
Paper/Polyester  
Foil Capacitors**

**Features —**

- Capacitance Values to 15 $\mu$ F
- Drawn Rectangular Metal Cases
- Solder lug or Pillar Terminals
- Voltage Ratings 400 to 12,500 VDC
- Approved to Mil-PRF-19978

**Major Applications:**

Bypass coupling, filtering in power supply, radar and other high voltage applications

**PHYSICAL CHARACTERISTICS —**

**Construction:**

Non-inductive wound paper/polyester film with extended foil electrodes

**Case:**

Hermetically sealed metal enclosure; styles available are shown in drawing above

**Terminals:**

See table II for the terminal available for each voltage and tables below for terminal description, number and size.

Symbol	Type of Terminal
B	Solder lug (non removable)
D, H	Pillar insulator (for use at altitudes up to 7,500 feet)
E	Pillar insulator (for use at altitudes up to 50,000 feet)

Terminal Number	Terminal Symbols	Terminal Dimensions			
		V max	Y min UNF-2A	Y max UNF-2A	Z
1	B	.75	-	-	.812
2	E	1.375	.190-32	.216-24	.812
3	E	1.75	.190-32	.216-24	1.000
4	D, E	2.75	.190-32	.3125-18	1.438
5	H	4.250	.375-16	.500-13	3.000

Shape of terminal B (drilled, punched, forked, or slotted) is optional.

Capacitors having terminal D or E shall be supplied with necessary terminal hardware for each terminal (two nuts, one of these may be a fixed nut on the top of the insulator, and one lock washer); in addition, capacitors rated at 3000 VDC or less shall be supplied with a solder lug capable of accommodating a No. 14 AWG wire for each terminal.

**Marking:**

Dearborn trademark, part number, capacitance, tolerance, voltage and date code

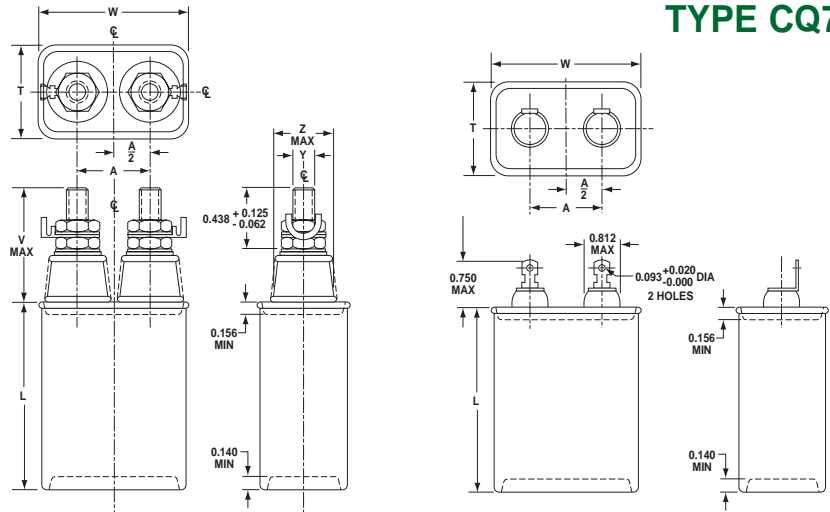

**ELECTRICAL SPECIFICATIONS —**

**Capacitance Range:**

0.10 $\mu$ F to 15.0 $\mu$ F

**DC Voltage Range:**

400 VDC to 12,500 VDC

**Capacitance Tolerance:**

K $\pm$ 10%

**Operating Temperature:**

Characteristic E -65°C to +85°C

Characteristic F -55°C to +85°C

Characteristic K -55°C to +125°C

**Voltage Derating:**

Characteristic E and F at +85°C 65% of rated voltage

Characteristic K at 125°C 70% of rated voltage

**Dissipation Factor:**

1.0% maximum

**Insulation Resistance:**

Measured at rated voltage or 500VDC whichever is less

**Table 1: Terminal to Terminal Insulation Resistance**

Capacitance Rating	Minimum Insulation Resistance
<b>Characteristic E</b> 0 to 0.6 microfarad Greater than 0.6 microfarad	<b>At 25°C</b> 25,000 megohms
	<b>At 85°C</b> 15,000 megohm-microfarads <sup>1/</sup>
	<b>At 125°C</b> 2,000 megohms
<b>Characteristic K</b> 0 to 0.15 microfarad Greater than 0.15 microfarad	<b>At 25°C</b> 300 megohm-microfarads <sup>1/</sup>
	<b>At 85°C</b> 25,000 megohms
	<b>At 125°C</b> 15,000 megohm-microfarads <sup>1/</sup>
<b>Characteristic F</b> 0 to 0.8 microfarad Greater than 0.08 microfarad	<b>At 25°C</b> 250 megohms
	<b>At 85°C</b> 20 megohm-microfarads <sup>1/</sup>
	<b>At 125°C</b> 20 megohm-microfarads <sup>1/</sup>
<b>Characteristic G</b> 0.33 microfarad and less Greater than 0.33 microfarad	<b>At 25°C</b> 6,000 megohms
	<b>At 85°C</b> 2,000 megohm-microfarads <sup>1/</sup>
	<b>At 125°C</b> 20 megohm-microfarads <sup>1/</sup>
<b>Characteristic H</b> 0.33 microfarad and less Greater than 0.33 microfarad	<b>At 25°C</b> 4,500 megohms
	<b>At 85°C</b> 1,500 megohm-microfarads <sup>1/</sup>
	<b>At 125°C</b> 15 megohm-microfarads <sup>1/</sup>
<b>Characteristic I</b> 0.033 microfarad and less Greater than 0.033 microfarad	<b>At 25°C</b> 450 megohms
	<b>At 85°C</b> 15 megohm-microfarads <sup>1/</sup>
	<b>At 125°C</b> 15 megohm-microfarads <sup>1/</sup>

<sup>1/</sup> Product obtained by multiplying capacitance in microfarads by the insulation resistance in megohms.

Table II Part number <sup>1/</sup>	DC voltage rating (Volts)	Capacitance (µF)	Vibration grade	Case size				Avail. terminal identification no.			
				Characteristic				Terminal			
				E	K	F	G	B	D	E	H
CQ72-1KE254K3	400	0.25	3	-	A1	-	-	1	-	2	-
CQ72-1-E504K3	400	0.5	3	A1	A2	-	-	1	-	2	-
CQ72-1-E105K3	400	1.0	3	A1	A3	-	-	1	-	2	-
CQ72-1-E205K3	400	2	3	A2	A5	-	-	1	-	2	-
CQ72-1-E405K3	400	4	3	B2	B6	-	-	1	-	2	-
CQ72-1-E605K3	400	6	3	B6	C3	-	-	1	-	2	-
CQ72-1-E805K3	400	8	3	C3	D4	-	-	1	-	2	-
CQ72-1-E106K3	400	10	3	C4	E4	-	-	1	-	2	-
CQ72-1-E126K3	400	12	3	D2	E6	-	-	1	-	2	-
CQ72-1-E156K3	400	15	3	D5	G4	-	-	1	-	2	-
CQ72-1FF254K1	600	0.25	1	-	-	A1	-	1	-	2	-
CQ72-1-F504K3	600	0.5	3	A1	A2	-	-	1	-	2	-
CQ72-1-F105K	600	1.0	1,3	A2	A3	-	-	1	-	2	-
CQ72-1-F205K	600	2	1,3	A2	B4	A4	A3	1	-	2	-
CQ72-1-F405K	600	4	1,3	B3	D2	B4	B3	1	-	2	-
CQ72-1-F605K	600	6	1,3	B6	E4	C2	B6	1	-	2	-
CQ72-1-F805K	600	8	1,3	C2	F1	C3	C2	1	-	2	-
CQ72-1-F106K	600	10	1,3	C4	J2	D3	C4	1	-	2	-
CQ72-1-F126K3	600	12	3	E2	J3	-	-	1	-	2	-
CQ72-1-F156K3	600	15	3	E5	J6	-	-	1	-	2	-
CQ72-1FG104K1	1,000	0.1	1	-	-	A1	-	1	-	2	-
CQ72-1-G254K	1,000	0.25	1,3	-	A2	A2	-	1	-	2	-
CQ72-1-G504K	1,000	0.5	1,3	A1	A3	A2	-	1	-	2	-
CQ72-1-G105K	1,000	1.0	1,3	A2	B3	A3	A2	1	-	2	-
CQ72-1-G205K	1,000	2	1,3	A5	C4	A6	A5	1	-	2	-
CQ72-1-G405K	1,000	4	1,3	B6	F1	C2	B6	1	-	2	-
CQ72-1-G605K	1,000	6	1,3	C4	G2	D3	C4	1	-	2	-
CQ72-1-G805K	1,000	8	1,3	D2	J2	D5	D2	1	-	2	-
CQ72-1-G106K	1,000	10	1,3	D5	J5	E5	D5	1	-	2	-
CQ72-1-G126K	1,000	12	1,3	E4	J6	E6	E4	1	-	2	-
CQ72-1-G156K	1,000	15	1,3	F1	J11	G2	F1	1	-	2	-
CQ72-1-H104K	1,500	0.1	1,3	A1	A1	A2	-	1	-	2	-
CQ72-1-H254K	1,500	0.25	1,3	A1	A2	A3	A2	1	-	2	-
CQ72-1-H504K	1,500	0.5	1,3	A2	A5	A3	-	1	-	2	-
CQ72-1-H105K	1,500	1.0	1,3	A5	B5	A6	A5	1	-	2	-
CQ72-1-H205K	1,500	2	1,3	B6	D4	B6	B5	1	-	2	-
CQ72-1-H405K	1,500	4	1,3	D5	G4	D4	C4	1	-	2	-
CQ72-1-H605K	1,500	6	1,3	G1	J6	E5	D5	1	-	2	-
CQ72-1-H805K	1,500	8	1,3	J2	J10	F2	F1	1	-	2	-
CQ72-1-H106K	1,500	10	1,3	J4	-	G4	G2	1	-	2	-
CQ72-1-H126K	1,500	12	1,3	J6	-	J3	G2	1	-	2	-
CQ72-1-H156K	1,500	15	1,3	J10	-	J6	J3	1	-	2	-
CQ72E1FJ254K1	2,000	0.25	1	-	-	B1	-	-	-	3	-
CQ72E1FJ504K1	2,000	0.5	1	-	-	B2	-	-	-	3	-
CQ72E1-J105K	2,000	1.0	1,3	-	C3	B6	B3	-	-	3	-
CQ72E1-J205K	2,000	2	1,3	C4	E6	C4	C3	-	-	3	-
CQ72E1-J405K	2,000	4	1,3	F1	J4	E6	E3	-	-	3	-
CQ72E1-J605K	2,000	6	1,3	G3	J8	G4	G1	-	-	3	-
CQ72E1-J805K	2,000	8	1,3	J2	-	J4	G3	-	-	3	-
CQ72E1-J106K	2,000	10	1,3	J5	-	J7	J3	-	-	3	-
CQ72E1-J126K	2,000	12	1,3	J6	-	J9	J5	-	-	3	-
CQ72E1-J156K	2,000	15	1,3	J11	-	J10	J7	-	-	3	-
CQ72E1FK104K1	2,500	0.1	1	-	-	B1	-	-	-	3	-
CQ72E1-K254K	2,500	0.25	1	-	-	B2	B1	-	-	3	-
CQ72E1-K504K	2,500	0.5	1,3	-	B5	B4	B3	-	-	3	-
CQ72E1-K105K	2,500	1.0	1,3	-	D2	D2	D1	-	-	3	-
CQ72E1-K205K	2,500	2	1,3	C4	G4	E5	D5	-	-	3	-
CQ72E1-K405K	2,500	4	1,3	E6	J8	J2	-	-	-	3	-
CQ72E1-K605K	2,500	6	1,3	J2	-	J6	J4	-	-	3	-
CQ72E1-K805K	2,500	8	1,3	J5	-	J8	J6	-	-	3	-
CQ72E1-K106K	2,500	10	1,3	J7	-	J10	J8	-	-	3	-
CQ72E1-K126K	2,500	12	1,3	J11	-	K3	J10	-	-	3	-
CQ72E1-L104K1	3,000	0.1	1	-	-	B2	B1	-	-	3	-
CQ72E1-L254K1	3,000	0.25	1	-	-	B3	B2	-	-	3	-
CQ72E1-L504K1	3,000	0.5	1	-	-	B6	B5	-	-	3	-
CQ72E1-L105K	3,000	1.0	1,3	D1	E4	E4	E3	-	-	3	-
CQ72E1-L205K	3,000	2	1,3	E2	J2	G2	G1	-	-	3	-
CQ72E1-L405K	3,000	4	1,3	G4	J11	J7	J3	-	-	3	-
CQ72E1-L605K	3,000	6	1,3	J5	-	K2	J9	-	-	3	-
CQ72E1FM104K1	4,000	0.1	1	-	-	E1	-	-	-	4	-
CQ72E1-M254K	4,000	0.25	1,3	-	C1	E3	E1	-	-	4	-
CQ72E1-M504K	4,000	0.5	1,3	-	C4	E5	E3	-	-	4	-
CQ72E1-M105K	4,000	1.0	1,3	C2	F2	G2	E6	-	-	4	-
CQ72E1-M205K	4,000	2	1,3	E6	J7	J6	J4	-	-	4	-
CQ72E1-M405K	4,000	4	1,3	J5	-	J11	J10	-	-	4	-
CQ72E1-N104K	5,000	0.1	1,3	C1	-	E1	-	-	-	4	-
CQ72E1-N254K	5,000	0.25	1,3	C1	-	E3	-	-	-	4	-
CQ72E1-N504K	5,000	0.5	1,3	C1	E4	E6	E4	-	-	4	-
CQ72E1-N105K	5,000	1.0	1,3	D2	G4	J4	J2	-	-	4	-
CQ72E1-N205K	5,000	2	1,3	F2	J11	J11	J6	-	-	4	-
CQ72E1-N405K1	5,000	4	1	-	-	K4	K3	-	-	4	-
CQ72D1-P104K	6,000	0.1	1,3	C1	-	E3	E2	-	-	4	-
CQ72D1-P254K	6,000	0.25	1,3	C1	D2	E5	E4	-	-	4	-
CQ72D1-P504K	6,000	0.5	1,3	C1	E6	J3	J2	-	-	4	-
CQ72D1-P105K	6,000	1.0	1,3	E5	J6	J11	J9	-	-	4	-

(Table II continued)

CQ72D1-P205K	6,000	2	1,3	G1	-	L1	K3	-	4	-	-
CQ72D1-R104K	7,500	0.1	1,3	C1	C1	E5	E3	-	4	-	-
CQ72D1-R254K	7,500	0.25	1,3	C2	G1	J2	J1	-	4	-	-
CQ72D1-R504K	7,500	0.5	1,3	E4	J3	J6	J4	-	4	-	-
CQ72D1-R105K	7,500	1.0	1,3	G3	-	K3	-	-	4	-	-
CQ72D1-R205K	7,500	2	1,3	J10	-	L2	K4	-	4	-	-
CQ72D1-S104K	10,000	0.1	1,3	C2	E2	-	-	-	4	-	-
CQ72D1-S254K	10,000	0.25	1,3	E2	J3	-	-	-	4	-	-
CQ72-1-S504K	10,000	0.5	1,3	F3	J9	K4	K3	-	4	-	5
CQ72-1-S105K	10,000	1.0	1,3	J6	-	L2	K4	-	4	-	5
CQ72-1-S205K1	10,000	2	1	-	-	M2	L3	-	4	-	5
CQ72-1-T104K	12,500	0.1	1,3	E2	J1	K1	-	-	4	-	5
CQ72-1-T254K	12,500	0.25	1,3	E4	J5	K2	-	-	4	-	5
CQ72-1-T504K	12,500	0.5	1,3	J4	-	L1	K4	-	4	-	5
CQ72-1-T105K	12,500	1.0	1,3	J10	-	M1	L3	-	4	-	5
CQ72-1-T205K1	12,500	2	1	-	-	M2	M1	-	4	-	5

<sup>1/</sup> Complete part number shall include additional symbols to indicate terminal, characteristic, and vibration grade, as applicable.

Table III Case size <sup>1/</sup>	Case Dimensions (in inches)				Retainer part number <sup>2/</sup>
	W±.062	T±.062	L±.062	A +.0625, -.187	
A1	1.812	1.062	1.625	0.812	CQ072-A1
A2	1.812	1.062	2.250	0.812	CQ072-A2
A3	1.812	1.062	2.875	0.812	CQ072-A3
A4	1.812	1.062	3.250	0.812	CQ072-A4
A5	1.812	1.062	3.875	0.812	CQ072-A5
A6	1.812	1.062	4.750	0.812	CQ072-A6
B1	2.500	1.188	2.500	1.125	CQ072-B1
B2	2.500	1.188	2.875	1.125	CQ072-B2
B3	2.500	1.188	3.500	1.125	CQ072-B3
B4	2.500	1.188	3.875	1.125	CQ072-B4
B5	2.500	1.188	4.250	1.125	CQ072-B5
B6	2.500	1.188	4.750	1.125	CQ072-B6
C1	3.750	1.250	3.250	2.000	CQ072-C1
C2	3.750	1.250	3.875	2.000	CQ072-C2
C3	3.750	1.250	4.250	2.000	CQ072-C3
C4	3.750	1.250	4.750	2.000	CQ072-C4
D1	3.750	1.750	3.250	2.000	CQ072-D1
D2	3.750	1.750	3.875	2.000	CQ072-D2
D3	3.750	1.750	4.000	2.000	CQ072-D3
D4	3.750	1.750	4.250	2.000	CQ072-D4
D5	3.750	1.750	4.750	2.000	CQ072-D5
E1	3.750	2.250	2.750	2.000	CQ072-E1
E2	3.750	2.250	3.375	2.000	CQ072-E2
E3	3.750	2.250	3.875	2.000	CQ072-E3
E4	3.750	2.250	4.500	2.000	CQ072-E4
E5	3.750	2.250	4.750	2.000	CQ072-E5
E6	3.750	2.250	5.125	2.000	CQ072-E6
F1	3.750	2.500	4.750	2.000	CQ072-F1
F2	3.750	2.500	5.750	2.000	CQ072-F2
G1	3.750	3.188	4.500	2.000	CQ072-G1
G2	3.750	3.188	4.750	2.000	CQ072-G2
G3	3.750	3.188	5.125	2.000	CQ072-G3
G4	3.750	3.188	5.500	2.000	CQ072-G4
J1	4.562	3.750	3.875	2.000	CQ072-J1
J2	4.562	3.750	4.375	2.000	CQ072-J2
J3	4.562	3.750	4.750	2.000	CQ072-J3
J4	4.562	3.750	5.125	2.000	CQ072-J4
J5	4.562	3.750	5.500	2.000	CQ072-J5
J6	4.562	3.750	6.000	2.000	CQ072-J6
J7	4.562	3.750	6.500	2.000	CQ072-J7
J8	4.562	3.750	7.000	2.000	CQ072-J8
J9	4.562	3.750	7.500	2.000	CQ072-J9
J10	4.562	3.750	8.500	2.000	CQ07