

# POLYESTER FILM CAPACITORS



<b>Metalized Polyester Film Capacitors, Typical Characteristics</b> . . . . .	B-3
Type 218P . . . . .	B-4
Type 430P . . . . .	B-7
Type 431P . . . . .	B-9
Type 442P . . . . .	B-11
<b>Polyester Film/Foil Capacitors, Typical Characteristics</b> . . . . .	B-14
Type 409P . . . . .	B-15
Type 410P . . . . .	B-17

## General Electrical, Physical, and Environmental Characteristics

### Test Procedures:

Section J of the catalog covers the applicable test procedures

### Electrical Characteristics:

Capacitance, Dissipation Factor, Insulation Resistance, and Dielectric Strength shall be measured as specified in section J

### Physical Characteristics:

The Lead Strength shall be measured as specified in section J

### Environmental Characteristics:

#### Vibration Test: (Condition B)

No mechanical damage, short, open or intermittent circuit

#### Moisture Resistance:

The hermetically sealed units shall be tested as outlined in the Moisture Resistance testing of section J. As a result of the test there shall be:

- No visible damage
- Max.  $\Delta C$  of  $\pm 10\%$
- Min. IR = 50% of initial limit
- Max. DF = 2.0%

### Humidity Test:

The Non-Hermetically sealed units shall be tested as outlined in section J "Humidity Test." As a result of the test there shall be:

- No visible damage
- Max.  $\Delta C$  of  $\pm 10\%$
- Min. IR = 20% of initial limit
- Max. DF = 2.0%

### DC Life:

125% of rated voltage at 85°C (125°C for 218P) for 250 hours except for 430P units rated at 1000 VDC or greater which shall be tested at 100% of rated voltage at 40°C for 1000 hours.

As a result of the test there shall be:

- No permanent open or short circuit
- No visible damage
- Max.  $\Delta C$  of  $\pm 10\%$
- Min. IR = 50% of initial limit
- Max. DF = 2.0%

**TYPICAL CHARACTERISTICS — METALIZED POLYESTER TYPES**

**CAPACITANCE CHANGE VS TEMPERATURE  
METALIZED POLYESTER**

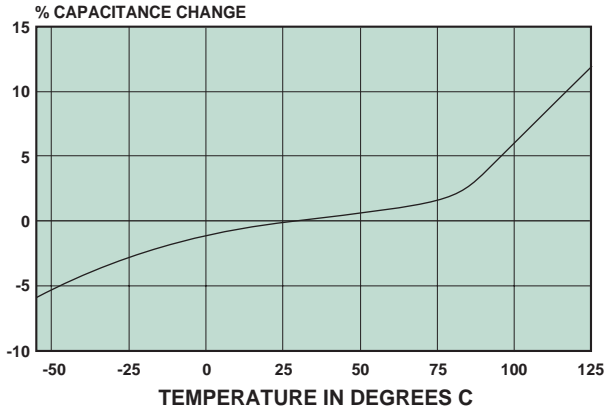

**CAPACITANCE CHANGE VS FREQUENCY  
METALIZED POLYESTER**

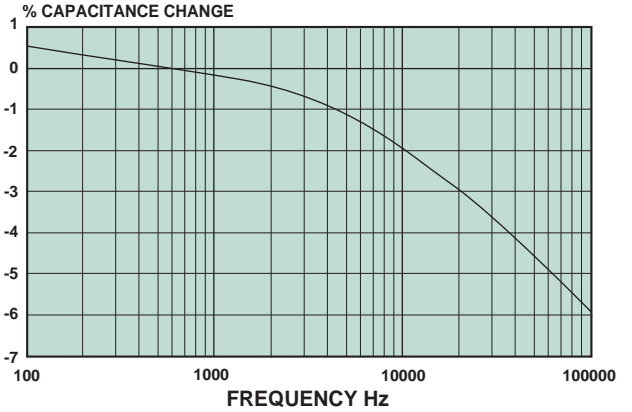

**DISSIPATION FACTOR VS TEMPERATURE  
METALIZED POLYESTER**

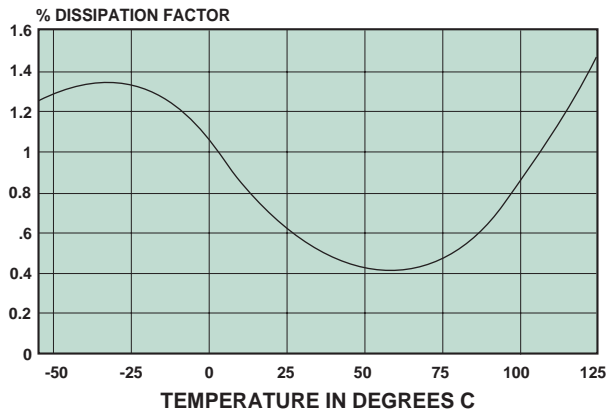

MEASURED AT 1kHz

**DISSIPATION FACTOR VS FREQUENCY  
METALIZED POLYESTER**

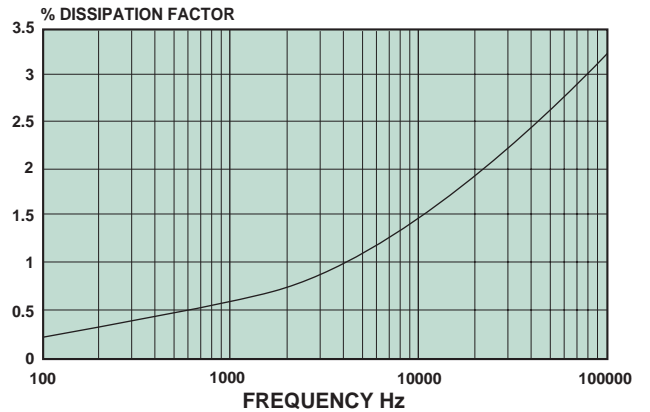

**INSULATION RESISTANCE VS TEMPERATURE  
METALIZED POLYESTER**

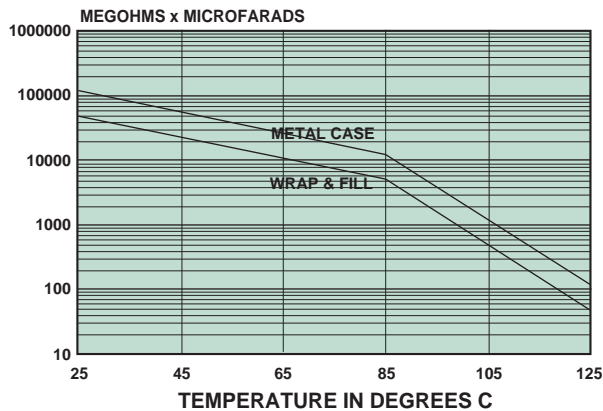

TYPICAL

**ELECTRICAL CHARACTERISTICS AS A FUNCTION OF TEMPERATURE AND FREQUENCY**

**Metal Case  
Hermetically-Sealed  
Metalized  
Polyester-Film Capacitors**

**TYPE 218P**

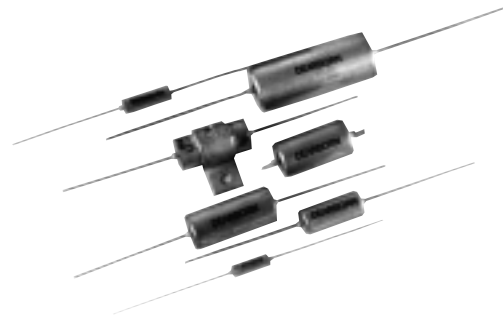

**Features —**

- Small Size
- Extensive Standard Ratings
- Wire Leads or Tab Terminals
- Approved to Mil-C-39022

**Major Applications:**

**Military and Industrial Applications where light weight and small size are combined with maximum protection against severe environments**

**PHYSICAL CHARACTERISTICS —**

**Construction:**

Non-inductive wound metalized polyester

**Case:**

Hermetically sealed metal enclosure. Styles available are shown in picture to the right and in the general section in the front of the catalog

**Lead Wire Sizes:**

Leads are solder coated solid wire

Can Dia.	Lead AWG
0.175 and 0.195	No. 24
0.235 and 0.312	No. 22
0.400 and over	No. 20

**Lead Strength:**

Capable of withstanding a five pound pull force on lead axis

**Marking:**

Dearborn trademark, type or catalog number, capacitance, tolerance and voltage

**ELECTRICAL SPECIFICATIONS —**

**Operating Temperature:**

-55°C to +125°C

**Capacitance Range:**

0.001µF to 12.0µF

**Voltage Range:**

100 VDC to 400 VDC  
63 VRMS to 200 VRMS

**Capacitance Tolerance:**

±20%, ±10%, ±5%

**Voltage Derating:**

No derating for DC operation  
For AC operation derate to 70% of the 85°C rating for operation up to 105°C

**Dissipation Factor:**

0.8% maximum ≤ 1.0µF  
1.0% maximum > 1.0µF

**Voltage Test:**

200% of rated voltage for 2 minutes

**Insulation Resistance:**

At +25°C, 50,000 Megohm-Microfarads, need not exceed 100,000 Megohms  
At +85°C, 3,000 Megohm-Microfarads, need not exceed 6,000 Megohms  
At +105°C, 250 Megohm-Microfarads, need not exceed 500 Megohms  
At +125°C, 10 Megohm-Microfarads, need not exceed 100 Megohms

**MAXIMUM PULSE RISE TIME**

Capacitor Length Inches	Rise Time dv/dt (V/µs)			
	100VDC/63VAC	150VDC/95VAC	200VDC/125VAC	400VDC/200VAC
0.750	57	78	135	225
0.875	36	48	51	185
1.125	18	27	31	75
1.375	13	20	24	-
1.625	10	15	19	48
1.875	9	14	15	30
2.125	-	10	-	25
2.375	6	9	12	-
2.625	-	7	10	21

**STANDARD RATINGS**

Capacitance μF	Capacitance code	Voltage code 100 100VDC/63VAC*		Voltage code 150 150VDC/95VAC*		Voltage code 200 200VDC/125VAC*		Voltage code 400 400VDC/200VAC*	
		D	L	D	L	D	L	D	L
0.0010	102	-	-	-	-	.175	.750	-	-
0.0015	152	-	-	-	-	.175	.750	-	-
0.0022	222	-	-	-	-	.175	.750	-	-
0.0033	332	-	-	-	-	.175	.750	-	-
0.0047	472	-	-	-	-	.175	.750	.235	.750
0.0068	682	-	-	-	-	.175	.750	.235	.750
0.010	103	.175	.750	.175	.750	.175	.750	.235	.750
0.015	153	.175	.750	.175	.750	.175	.750	.312	.875
0.022	223	.175	.750	.195	.750	.195	.750	.312	.875
0.033	333	.175	.750	.195	.750	.235	.750	.312	.875
0.047	473	.195	.750	.235	.750	.235	.750	.400	.875
0.068	683	.235	.750	.235	.750	.312	.875	.400	1.125
0.10	104	.235	.750	.312	.875	.312	.875	.400	1.125
0.15	154	.312	.875	.312	.875	.312	.875	.500	1.125
0.22	224	.312	.875	.312	.875	.400	.875	.562	1.125
0.33	334	.312	.875	.312	1.125	.400	1.125	.562	1.625
0.47	474	.312	1.125	.400	1.125	.400	1.375	.562	1.875
0.68	684	.400	1.125	.400	1.125	.500	1.125	.670	1.875
1.00	105	.400	1.125	.500	1.125	.562	1.375	.750	2.125
1.50	155	.500	1.125	.562	1.125	.562	1.625	.750	2.625
2.00	205	.562	1.125	.562	1.375	.562	1.875	1.000	2.125
2.50	255	.562	1.375	.562	1.625	.670	1.625	1.000	2.625
3.00	305	.562	1.375	.670	1.375	.670	1.875	-	-
4.00	405	.562	1.625	.670	1.625	.750	1.875	-	-
5.00	505	.562	1.875	.670	1.875	.750	2.375	-	-
6.00	605	.670	1.625	.750	1.875	.750	2.625	-	-
7.00	705	.670	1.875	.750	2.125	1.000	1.875	-	-
10.00	106	.750	1.875	.750	2.625	1.000	2.375	-	-
12.00	126	.750	2.375	1.000	1.875	1.000	2.625	-	-

Additional capacitance values, voltages, and tolerances are available upon request.

The dimensions shown are for style 02. The dimensions for other styles are included in the general section.

\* AC voltage rating is at 60Hz. 1.4 x VRMS + VDC should not exceed the rated VDC.

\* Graphs of AC voltage vs frequency follow.

**VOLTAGE vs FREQUENCY TYPE 218P  
100VDC\63VAC**

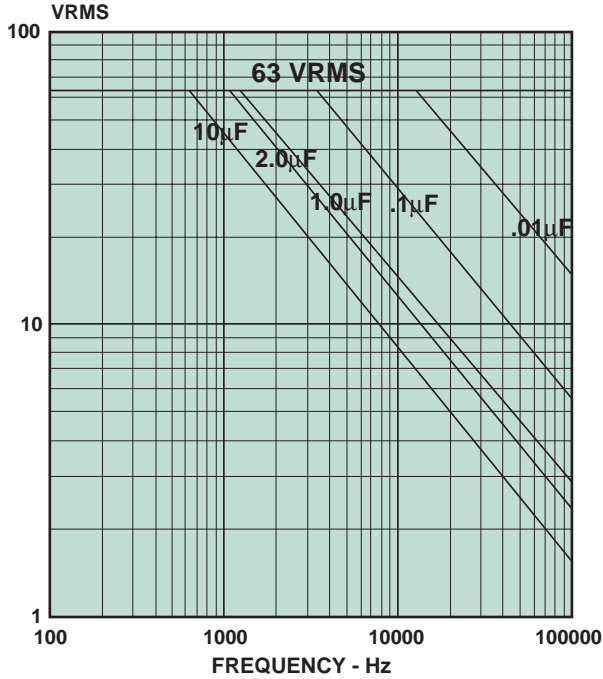

**VOLTAGE vs FREQUENCY TYPE 218P  
150VDC\95VAC**

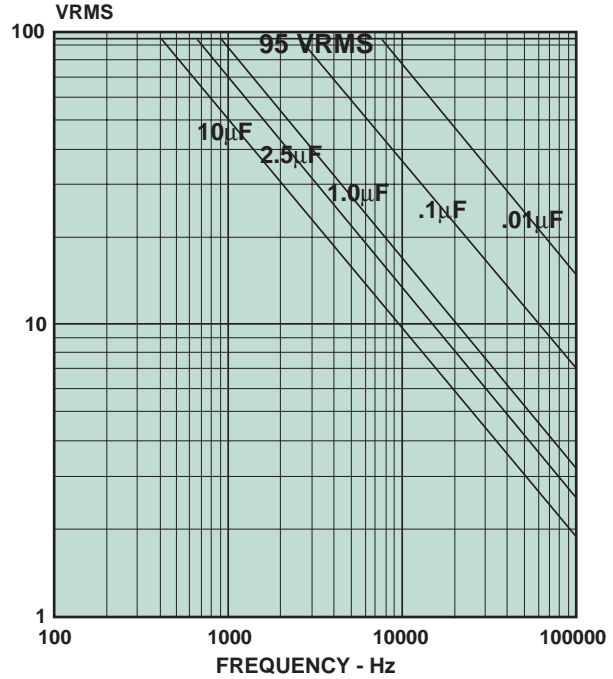

**VOLTAGE vs FREQUENCY TYPE 218P  
200VDC\125VAC**

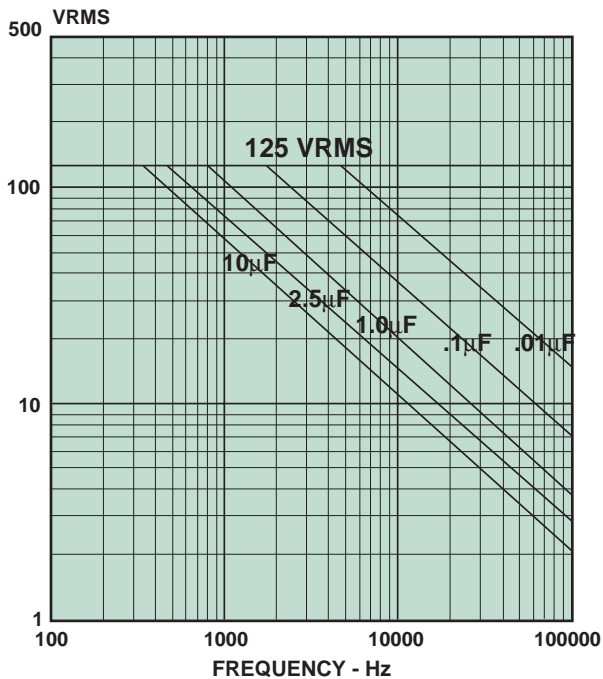

**VOLTAGE vs FREQUENCY TYPE 218P  
400VDC\200VAC**

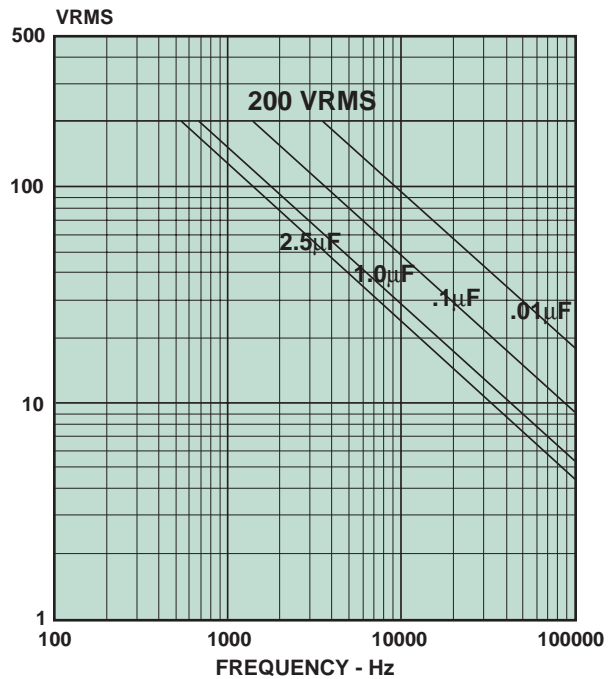

# Wrap-and-Fill Metalized Polyester Film Capacitors

**Features —**

- 63 VDC-16,000 VDC
- Extensive Standard Ratings
- Rugged Construction
- Small Size

**Major Applications:**

Blocking, filtering, bypass, timing, coupling decoupling, pulse operations, power supply, low to high voltage, copiers, etc.

## PHYSICAL CHARACTERISTICS —

**Construction:**

Non-inductive wound metalized polyester

**Case:**

Flame retardant tape wrap and epoxy end fill

**Lead Material:**

Solder coated solid wire

**Lead Strength:**

Capable of withstanding a five pound pull force on lead axis

**Marking:**

Dearborn trademark, type or catalog number, capacitance, tolerance and voltage

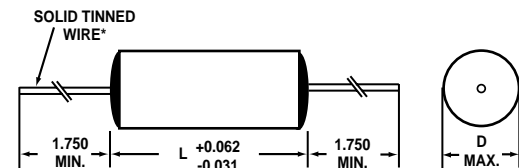
**DIMENSIONS IN INCHES**

\*Lead Size  
 D MAX < 0.270 0.025 (no. 22 AWG)  
 D MAX ≥ 0.270 0.032 (No. 20 AWG)

\*Leads to be within ± 0.062" (1.57 mm) of the center line at egress, but not less than 0.031" for the edge.

## ELECTRICAL SPECIFICATIONS —

**Capacitance Range:**

0.001μF to 10.0μF

**Voltage Range:**

63 VDC to 16000 VDC  
 40 VAC to 220 VAC

**Capacitance Tolerance:**

±20%, ±10%, ±5%

**Operating Temperature:**

-55°C to +125°C

**Voltage Derating:**

At +125°C, 50% of the 85°C rating

**Dissipation Factor:**

0.8% maximum ≤ 1.0μF  
 1.0% maximum > 1.0μF

**Voltage Test:**

200% of rated voltage for 2 minutes. 1kv and greater voltage limited to 120% of rated voltage for 5 min. thru 50,000 ohms minimum

**Insulation Resistance:**

At +25°C, 25,000 Megohm-Microfarads, need not exceed 50,000 Megohms  
 At +85°C, 1,000 Megohm-Microfarads, need not exceed 2,500 Megohms

## MAXIMUM PULSE RISE TIME

Capacitor Length Inches	Rise Time dv/dt (V/μs)											
	63VDC	100 VDC	250VDC	400VDC	630VDC	1000VDC	2000VDC	4000VDC	6000VDC	8000VDC	10000VDC	16000VDC
0.625	46	51	75	100	250	-	-	-	-	-	-	-
0.750	28	34	48	75	130	-	-	-	-	-	-	-
1.000	16	19	27	45	75	89	170	-	-	-	-	-
1.125	-	-	-	-	-	-	-	1200	-	-	-	-
1.250	12	13	19	30	45	-	-	-	-	-	-	-
1.500	9	10	15	21	35	-	-	-	2750	-	-	-
1.750	-	9	12	19	25	30	50	450	-	-	-	-
1.875	-	-	-	-	-	-	-	-	-	5000	-	-
2.000	-	-	-	-	25	-	-	-	-	-	-	-
2.250	-	-	-	-	-	-	-	-	-	-	7500	-
2.500	-	-	-	-	-	-	-	-	1000	-	-	-
3.062	-	-	-	-	-	-	-	-	-	-	-	12000
3.187	-	-	-	-	-	-	-	-	-	1900	-	-

**STANDARD RATINGS**

Cap. $\mu$ F	Cap. code	Voltage code 063 63VDC/ 40VAC*		Voltage code 100 100VDC/ 63VAC*		Voltage code 250 250 VDC/ 160 VAC*		Voltage code 400 400 VDC/ 200 VAC*		Voltage code 630 630 VDC/ 220 VAC*		Voltage code 1k0 1000 VDC	
		D	L	D	L	D	L	D	L	D	L	D	L
0.0047	472	-	-	-	-	-	-	-	-	.187	.625	-	-
0.0068	682	-	-	-	-	-	-	-	-	.209	.625	-	-
0.010	103	-	-	-	-	-	-	-	-	.239	.625	-	-
0.015	153	-	-	-	-	-	-	.186	.625	.224	.750	-	-
0.022	223	-	-	-	-	-	-	.210	.625	.257	.750	-	-
0.033	333	-	-	-	-	-	-	.241	.625	.300	.750	-	-
0.047	473	-	-	-	-	.200	.625	.275	.625	.269	1.000	.302	1.000
0.068	683	-	-	-	-	.225	.625	.266	.750	.311	1.000	.347	1.000
0.10	104	-	-	.204	.625	.221	.750	.310	.750	.365	1.000	.405	1.000
0.15	154	.210	.625	.233	.625	.254	.750	.293	1.000	.368	1.250	.489	1.000
0.22	224	.240	.625	.228	.750	.295	.750	.342	1.000	.385	1.500	.574	1.000
0.33	334	.279	.625	.264	.750	.279	1.000	.350	1.250	.428	1.750	.457	1.750
0.47	474	.269	.750	.246	1.000	.321	1.000	.364	1.500	.497	1.750	.528	1.750
0.68	684	.311	.750	.283	1.000	.375	1.000	.402	1.750	.585	1.750	.618	1.750
1.00	105	.291	1.000	.286	1.250	.380	1.250	.472	1.750	-	-	.733	1.750
1.50	155	.344	1.000	.351	1.250	.454	1.250	.563	1.750	-	-	-	-
2.00	205	.400	1.000	.393	1.250	.469	1.500	.640	1.750	-	-	-	-
2.50	255	.438	1.000	.430	1.250	.516	1.500	-	-	-	-	-	-
3.00	305	.398	1.250	.464	1.250	.559	1.500	-	-	-	-	-	-
4.00	405	.434	1.500	.494	1.500	.580	1.750	-	-	-	-	-	-
5.00	505	.476	1.500	.544	1.500	.641	1.750	-	-	-	-	-	-
6.00	605	.515	1.500	.591	1.500	.697	1.750	-	-	-	-	-	-
7.00	705	.551	1.500	.633	1.500	-	-	-	-	-	-	-	-
10.00	106	.647	1.500	.678	1.750	-	-	-	-	-	-	-	-

Cap. $\mu$ F	Cap. code	Voltage code 2K0 2000VDC		Voltage code 4K0 4000VDC		Voltage code 6K0 6000 VDC		Voltage code 8K0 8000 VDC		Voltage code 10k0 10000 VDC		Voltage code 16k0 16000 VDC	
		D	L	D	L	D	L	D	L	D	L	D	L
0.0010	102	-	-	.301	1.125	.304	1.500	.294	1.875	.337	2.250	.387	3.062
0.0015	152	-	-	.301	1.125	.304	1.500	.342	1.875	.360	2.250	.451	3.062
0.0022	222	-	-	.301	1.125	.333	1.500	.371	1.875	.360	2.250	.528	3.062
0.0033	332	-	-	.326	1.125	.381	1.500	.371	1.875	.417	2.250	.628	3.062
0.0047	472	-	-	.326	1.125	.381	1.500	.429	1.875	.480	2.250	.734	3.062
0.0068	682	-	-	.376	1.125	.445	1.500	.510	1.875	.560	2.250	.868	3.062
0.010	103	-	-	.440	1.125	.531	1.500	.600	1.875	.662	2.250	1.040	3.062
0.015	153	.309	1.000	.531	1.125	.632	1.500	.717	1.875	.793	2.250	1.353	3.062
0.022	223	.358	1.000	.407	1.750	.749	1.500	.853	1.875	.946	2.250	-	-
0.033	333	.421	1.000	.490	1.750	.581	2.500	1.030	1.875	-	-	-	-
0.047	473	.497	1.000	.568	1.750	.678	2.500	.771	1.875	-	-	-	-
0.068	683	.581	1.000	.667	1.750	.800	2.500	.913	3.187	-	-	-	-
0.10	104	.413	1.750	.793	1.750	1.009	2.500	-	-	-	-	-	-
0.15	154	.498	1.750	.956	1.750	-	-	-	-	-	-	-	-
0.22	224	.585	1.750	1.143	1.750	-	-	-	-	-	-	-	-
0.33	334	.699	1.750	-	-	-	-	-	-	-	-	-	-

Additional Capacitance values, voltages, and tolerances are available upon request.  
 \*AC voltage rating is at 60Hz. 1.4 x VRMS + VDC should not exceed the rated VDC.

**Wrap-and-Fill  
Oval Configuration  
Metalized Polyester  
Film Capacitors**

**Features —**

- Economical
- Small Size
- Rugged Construction
- Space Saving Oval Configuration

**Major Applications:**

Blocking, filtering, bypass, timing, coupling  
decoupling, pulse operations, power supply, etc.

**PHYSICAL CHARACTERISTICS —**

**Construction:**

Non-inductive wound metalized polyester

**Case:**

Flame retardant tape wrap and epoxy end fill

**Lead Material:**

Solder coated solid wire

**Lead Strength:**

Capable of withstanding a five pound pull force on lead axis

**Marking:**

Dearborn trademark, type or catalog number, capacitance,  
tolerance and voltage

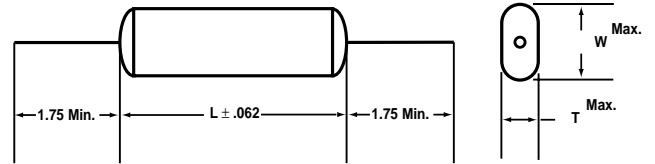

Leads are bare, solder coated solid wire. Lead wire sizes are:

Case size	Lead AWG
T Max < 0.240	No. 22
T Max > 0.240	No. 20

\*Leads to be within ± 0.062" (1.57 mm) of the center line at egress, but not less than 0.031" for the edge.

**ELECTRICAL SPECIFICATIONS —**

**Capacitance Range:**

0.01µF to 15.0µF

**Voltage Rating:**

63 VDC to 630 VDC  
40 VRMS to 220 VRMS

**Capacitance Tolerance:**

±20%, ±10%, ±5%

**Operating Temperature:**

-55°C to +125°C

**Voltage Derating:**

At +125°C, 50% of the 85°C rating

**Dissipation Factor:**

0.8% maximum ≤ 1.0µF  
1.0% maximum > 1.0µF

**DC Voltage Test:**

200% of rated voltage for 2 minutes

**Insulation Resistance:**

At +25°C, 25,000 Megohm-Microfarads,  
need not exceed 50,000 Megohms

At +85°C, 1,000 Megohm-Microfarads,  
need not exceed 2,500 Megohms

**MAXIMUM PULSE RISE TIME**

Capacitor Length Inches	Rise Time dv/dt (V/µs)				
	63VDC/40VAC	100VDC/63VAC	250VDC/160VAC	400VDC/200VAC	630VDC/220VAC
0.625	46	54	75	100	250
0.750	28	34	48	75	130
1.000	16	19	27	45	75
1.250	12	13	19	30	45
1.500	9	10	15	-	37
1.750	9	9	12	19	30
2.000	-	-	-	-	25
2.250	-	7	9	13	-

STANDARD RATINGS

Capacitance µF	Capacitance code	Voltage code 063 63VDC/40VAC*			Voltage code 100 100VDC/63VAC*			Voltage code 250 250VDC/160VAC*		
		T	W	L	T	W	L	T	W	L
0.010	103	-	-	-	-	-	-	-	-	-
0.015	153	-	-	-	-	-	-	-	-	-
0.022	223	-	-	-	-	-	-	-	-	-
0.033	333	-	-	-	-	-	-	-	-	-
0.047	473	-	-	-	-	-	-	-	-	-
0.068	683	-	-	-	-	-	-	-	-	-
0.10	104	-	-	-	-	-	-	.191	.298	.625
0.15	154	-	-	-	-	-	-	.186	.293	.750
0.22	224	-	-	-	.200	.307	.625	.215	.347	.750
0.33	334	.210	.317	.625	.196	.303	.750	.200	.332	1.000
0.47	474	.191	.323	.750	.178	.285	1.000	.231	.387	1.000
0.68	684	.231	.363	.750	.204	.336	1.000	.282	.438	1.000
1.00	105	.212	.344	1.000	.208	.339	1.250	.287	.443	1.250
1.50	155	.252	.408	1.000	.246	.403	1.250	.336	.541	1.250
2.00	205	.274	.480	1.000	.288	.444	1.250	.341	.547	1.500
2.50	255	.311	.517	1.000	.304	.509	1.250	.366	.628	1.500
3.00	305	.283	.488	1.250	.337	.542	1.250	.407	.662	1.500
4.00	405	.307	.513	1.250	.345	.600	1.500	.427	.682	1.750
5.00	505	.349	.554	1.500	.393	.648	1.500	.486	.741	1.750
6.00	605	.365	.620	1.500	.437	.692	1.500	.496	.848	1.750
7.00	705	.400	.654	1.500	.479	.733	1.500	.544	.897	1.750
10.00	106	.492	.747	1.500	.478	.831	1.750	.558	.910	2.250
12.00	126	.496	.740	1.750	.483	.738	2.250	.622	.975	2.250
15.00	156	.507	.860	1.750	.505	.857	2.250	-	-	-

STANDARD RATINGS (Con't.)

Capacitance µF	Capacitance code	Voltage code 400 400VDC/200VAC*			Voltage code 630 630VDC/220VAC*		
		T	W	L	T	W	L
0.010	103	-	-	-	.171	.278	.625
0.015	153	-	-	-	.199	.331	.625
0.022	223	-	-	-	.189	.296	.750
0.033	333	.173	.280	.625	.221	.353	.750
0.047	473	.206	.313	.625	.191	.323	1.000
0.068	683	.198	.305	.750	.231	.363	1.000
0.10	104	.230	.362	.750	.272	.429	1.000
0.15	154	.214	.395	1.000	.275	.432	1.250
0.22	224	.251	.407	1.000	.292	.448	1.500
0.33	334	.258	.415	1.250	.302	.507	1.750
0.47	474	.272	.428	1.500	.348	.603	1.750
0.68	684	.297	.453	1.750	.432	.687	1.750
1.00	105	.344	.550	1.750	.488	.742	2.000
1.50	155	.411	.665	1.750	-	-	-
2.00	205	.486	.740	1.750	-	-	-
2.50	255	.507	.860	1.750	-	-	-
3.00	305	.467	.820	2.250	-	-	-
4.00	405	.557	.910	2.250	-	-	-

Additional capacitance values, voltages, and tolerances are available upon request.

\* AC voltage rating is at 60Hz. 1.4 times the RMS Voltage plus the DC voltage should not exceed the rated VDC.

**Wrap-and-Fill  
Metalized Polyester  
Film Capacitors**

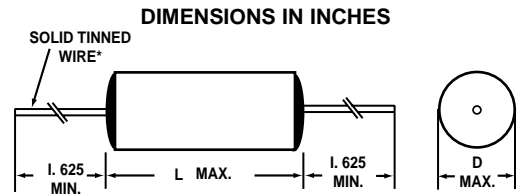

\*Lead Size  
 D MAX < 0.270 0.025 (no. 22 AWG)  
 D MAX ≥ 0.270 0.032 (No. 20 AWG)

\*Leads to be within ± 0.062" (1.57 mm) of the center line at egress, but not less than 0.031" for the edge.

**Features —**

- Smallest Polyester Capacitor Available
- Wide Temperature Range
- Rated for DC and AC Operation
- Capacitance Values to 10µF

**Major Applications:**

**Blocking, filtering, bypass, timing, coupling  
decoupling, pulse operations, power supplies**

**PHYSICAL CHARACTERISTICS —**

**Construction:**

Non-inductive wound metalized polyester

**Case:**

Flame retardant tape wrap and epoxy end fill

**Lead Material:**

Solder coated solid wire

**Lead Strength:**

Capable of withstanding a five pound pull force on lead axis

**Marking:**

Dearborn trademark, type or catalog number, capacitance, and voltage

**ELECTRICAL SPECIFICATIONS —**

**Capacitance Range:**

0.01µF to 10.0µF

**Voltage Range:**

63 VDC to 400 VDC  
40 VAC to 200 VAC

**Capacitance Tolerance:**

±20%, ±10%, ±5%

**Operating Temperature:**

-55°C to +125°C

**Voltage Derating:**

At +125°C, 50% of the 85°C rating

**Dissipation Factor:**

0.9% maximum

**DC Voltage Test:**

200% of rated voltage for 2 minutes

**Insulation Resistance:**

At +25°C, 25,000 Megohm-Microfarads,  
need not exceed 50,000 Megohms

At +85°C, 1,000 Megohm-Microfarads,  
need not exceed 2,500 Megohms

**MAXIMUM PULSE RISE TIME**

Capacitor Length Inches	Rise Time dv/dt (V/µs)			
	63VDC	100VDC	250VDC	400VDC
0.450	20	40	80	-
0.580	15	20	40	80
0.700	10	15	-	50
0.830	8	10	20	40
1.00	6	8	15	30
1.20	-	6	10	20
1.50	-	-	-	15
1.70	-	-	8	-
1.95	-	-	8	10

**STANDARD RATINGS**

Capacitance μF	Capacitance code	Voltage code 063 63VDC/40VAC*		Voltage code 100 100VDC/63VAC*		Voltage code 250 250VDC/160VAC*		Voltage code 400 400VDC/200VAC*	
		D	L	D	L	D	L	D	L
0.010	103	-	-	-	-	.200	.450	.200	.580
0.015	153	-	-	-	-	.200	.450	.200	.580
0.022	223	-	-	-	-	.200	.450	.230	.580
0.033	333	-	-	-	-	.200	.450	.270	.580
0.047	473	-	-	-	-	.230	.450	.300	.580
0.068	683	-	-	.200	.450	.230	.580	.290	.700
0.10	104	-	-	.200	.450	.270	.580	.330	.700
0.15	154	-	-	.210	.450	.310	.580	.340	.830
0.22	224	.200	.450	.240	.450	.340	.580	.400	.830
0.33	334	.230	.450	.230	.580	.340	.830	.430	1.00
0.47	474	.260	.450	.260	.580	.390	.830	.440	1.20
0.68	684	.240	.580	.290	.580	.370	1.00	.510	1.20
1.00	105	.280	.580	.350	.580	.430	1.00	.600	1.20
1.50	155	.320	.580	.360	.700	.510	1.00	.640	1.50
2.20	225	.380	.580	.380	.830	.530	1.20	.650	1.95
3.30	335	.380	.700	.460	.830	.630	1.20	.780	1.95
5.00	505	.460	.700	.510	1.00	.740	1.20	.910	1.95
6.00	605	.500	.830	.440	1.20	.640	1.70	-	-
8.00	805	.510	1.00	.500	1.20	.690	1.95	-	-
10.00	106	.560	1.00	.620	1.20	.860	1.95	-	-

Additional capacitance values, voltages, and tolerances are available upon request.

\* AC voltage rating is at 60Hz. 1.4 x VRMS + VDC should not exceed the rated VDC.

\* Graphs of AC voltage vs frequency follow.

**VOLTAGE vs FREQUENCY TYPE 442P  
63VDC\40VAC**

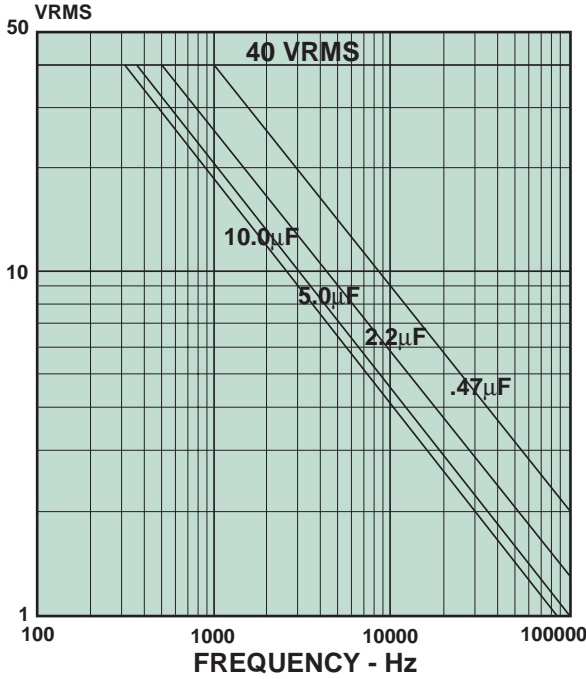

**VOLTAGE vs FREQUENCY TYPE 442P  
100VDC\63VAC**

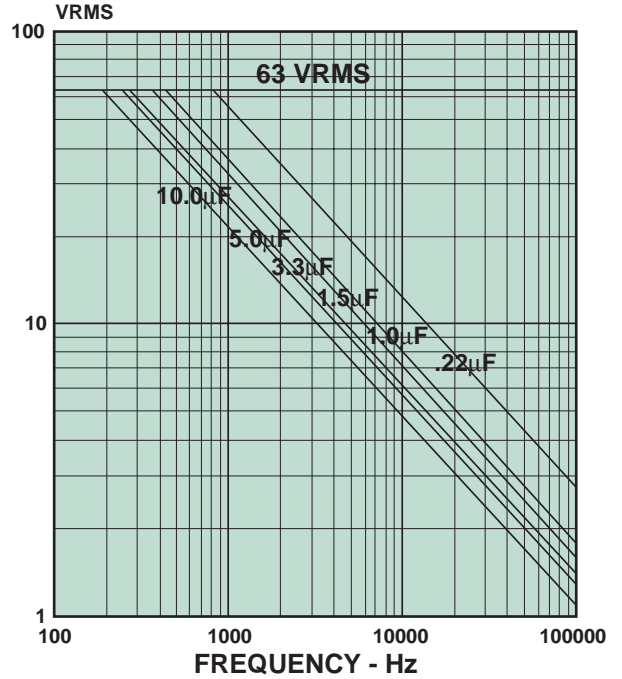

**VOLTAGE vs FREQUENCY TYPE 442P  
250VDC\160VAC**

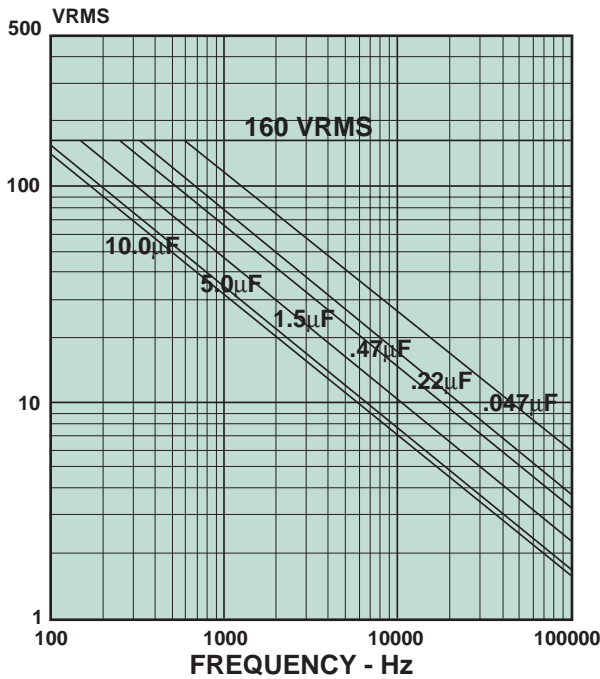

**VOLTAGE vs FREQUENCY TYPE 442P  
400VDC\200VAC**

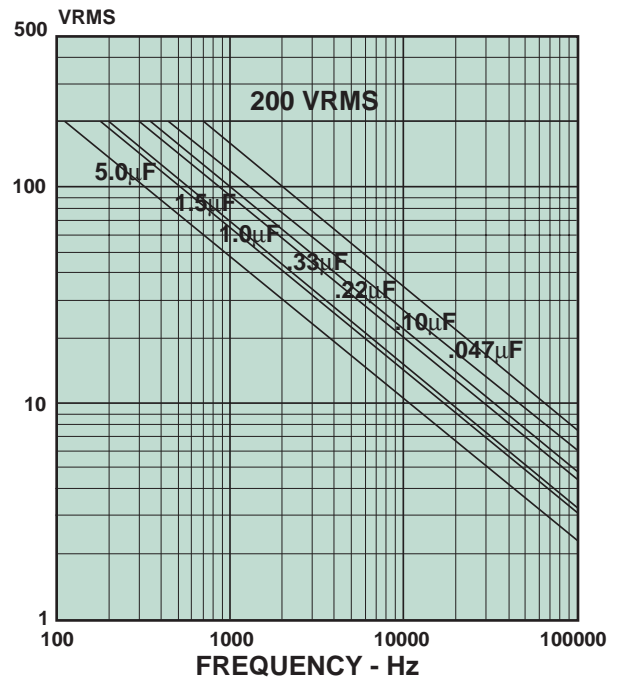

**TYPICAL CHARACTERISTICS — POLYESTER FILM/FOIL TYPES**

**CAPACITANCE CHANGE VS TEMPERATURE  
POLYESTER FILM/FOIL**

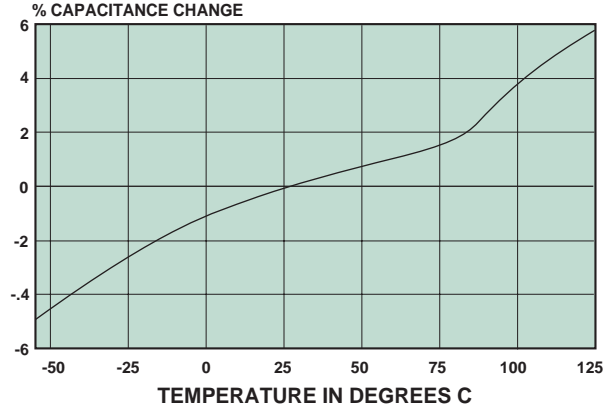

**DISSIPATION FACTOR VS TEMPERATURE  
POLYESTER FILM/FOIL**

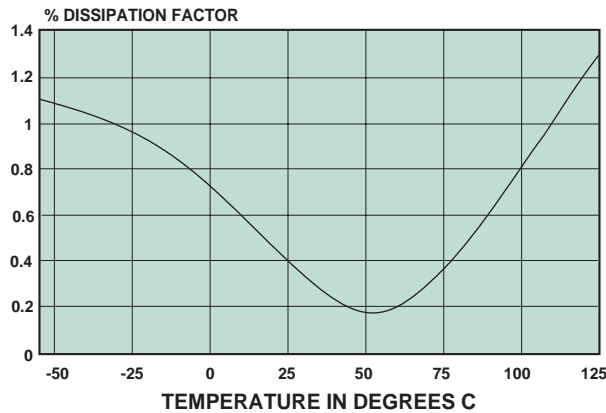

MEASURED AT 1kHz

**INSULATION RESISTANCE VS TEMPERATURE  
POLYESTER FILM/FOIL**

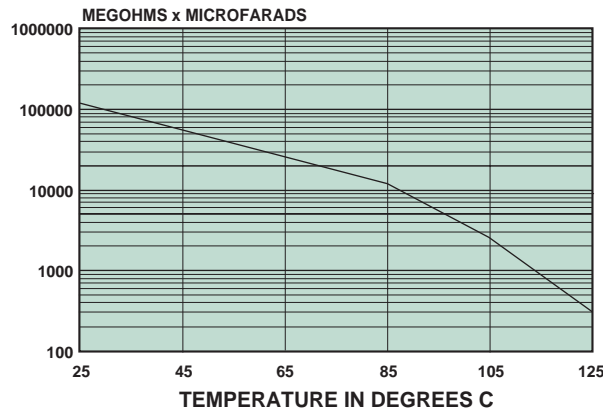

TYPICAL

**ELECTRICAL CHARACTERISTICS AS A FUNCTION OF TEMPERATURE**

**Metal Case  
Hypass™ Interference  
Suppression Polyester  
Film Capacitors**

**Features —**

- High Frequency Filtering
- No Series Resonance
- Low Inductance to Ground

**Major Application: EMI Suppression**

**PHYSICAL CHARACTERISTICS —**

**Markings:**

Dearborn trademark, type or catalog number, capacitance and voltage

**Torque:**

Terminals shall withstand 10 inch pounds with no damage

**Dimensions:**

See chart below, contact factory for additional sizes

**ENVIRONMENTAL CHARACTERISTICS —**

**DC Life Test:**

150% of rated DC voltage for 250 hours at +85°C

No open or short circuits

No visible damage

Max. Cap chg: ±5%

Min. I.R. = 50% of initial limit

Max. D.F. = 2.0%

**Thermal Shock and Immersion Cycling:**

No visible damage

Max. Cap chg: ±5%

Min. I.R. = 50% of initial limit

Max. D.F. = 2.0%

**INSERTION LOSS OF A HYPASS™ CAPACITOR  
VERSUS A CONVENTIONAL CAPACITOR**

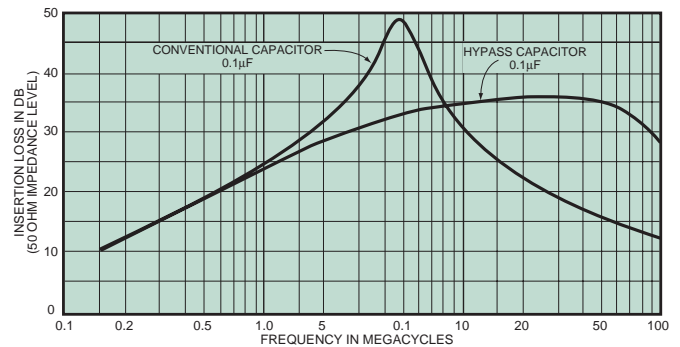

**ELECTRICAL SPECIFICATIONS —**

**Capacitance Range:**

0.10µF to 0.5µF

**DC Voltage Rating:**

50VDC to 1,000 VDC

**Capacitance Tolerance:**

+20% - 10%, ±10%

**Operating Temperature:**

-40°C to +85°C

**Dissipation Factor:**

1.0% maximum

**Voltage Test:**

200% of rated voltage for 1 minute

**Insulation Resistance:**

At +25°C, 20,000 Megohm-Microfarads, need not exceed 20,000 Megohms

At +85°C, 200 Megohm-Microfarads, need not exceed 1,000 Megohms

**TYPICAL SIZES**

BRACKET MOUNTING								BULKHEAD MOUNTING							
Current µF in Amps	Dimensions							Current µF in Amps	Dimensions						
	D	L	W	M	R	Y	Fig.		D	L	W	M	R	Y	Fig.
<b>50 WVDC</b>								<b>200 WVDC</b>							
0.50 40	1.000	1.813	1.000	0.875	1.188	0.250	1	0.25 20	0.750	1.813	0.875	1.125	1.438	0.156	2
0.50 60	1.000	1.813	1.000	0.875	1.188	0.250	1								
<b>200 WVDC</b>								<b>400 WVDC</b>							
0.25 20	0.750	1.813	0.750	0.656	0.875	0.201	1	0.10 20	0.688	1.813	0.875	1.062	1.375	0.156	2
0.50 20	1.000	1.813	1.000	0.875	1.188	0.250	1								
<b>400 WVDC</b>								<b>600 WVDC</b>							
0.10 20	0.688	1.813	0.750	0.641	0.781	0.201	1	0.10 20	0.688	1.813	0.875	1.062	1.375	0.156	2
<b>600 WVDC</b>								<b>1000 WVDC</b>							
0.10 20	0.688	1.813	0.750	0.641	0.781	0.201	1	0.50 100	1.125	3.125	1.500	1.750	2.312	0.201	3
0.25 20	1.000	1.813	1.000	0.875	1.188	0.250	1								
0.50 20	1.000	2.250	1.000	0.875	1.188	0.250	1								

Note: Hypass capacitors rated at 200 WVDC or 400 WVDC may be used on 130 volt, 60 Hz circuits. Capacitors rated at 600 and 1000 WVDC may be used on 250 volt, 60 Hz circuits.

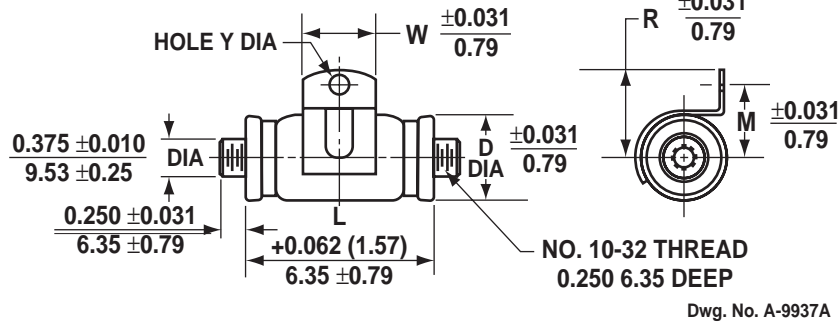

FIGURE 1

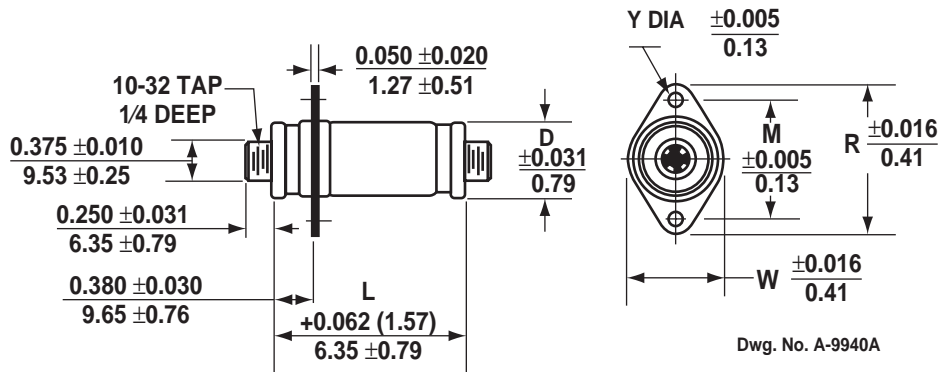

FIGURE 2

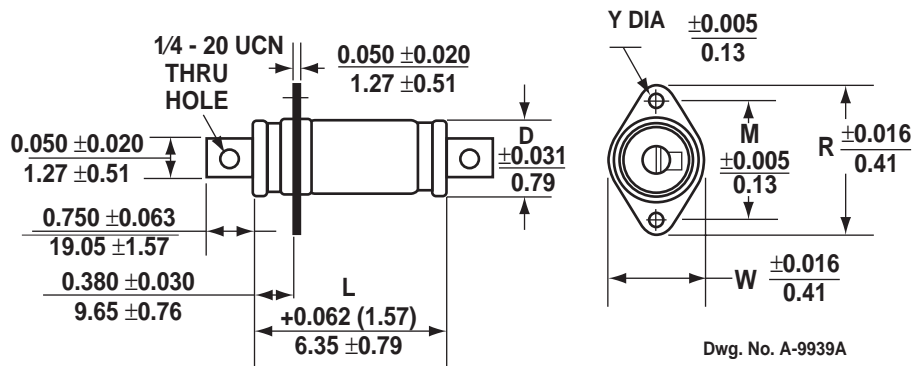

FIGURE 3

Dimensions:  $\frac{\text{Inches}}{\text{Millimeters}}$

Terminal Hardware Available on Special Order.

**Wrap-and-Fill  
Polyester Dielectric  
Film/Foil Construction**

**Features —**

- Extended Foil Construction
- Moisture Resistant

**PHYSICAL CHARACTERISTICS —**

**Construction:**

Non-inductive wound polyester film and foil

**Case:**

Flame retardant tape wrap and epoxy end fill

**Lead Material:**

Solder coated solid wire

**Lead Pull:**

Capable of withstanding a five pound pull force on lead axis

**Marking:**

Dearborn trademark, type or catalog number, capacitance and voltage

**ELECTRICAL SPECIFICATIONS —**

**Capacitance Range:**

0.001 $\mu$ F to 5.0 $\mu$ F

**Voltage Rating:**

50 VDC to 600 VDC

32 VAC to 220 VAC

**Capacitance Tolerance:**

$\pm$ 20%,  $\pm$ 10%,  $\pm$ 5%

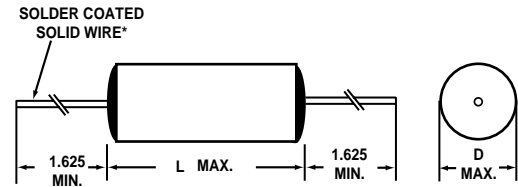

\*Lead Size  
 D MAX  $\leq$  0.437 0.025 (no. 22 AWG)  
 D MAX  $>$  0.437 0.032 (No. 20 AWG)

\*Leads to be within  $\pm$  0.062" (1.57 mm) of the center line at egress, but not less than 0.031" for the edge

**Operating Temperature:**

-55°C to +125°C

**Dissipation Factor:**

1.0%, maximum

**Voltage Derating:**

At +105°C, 70% of the 85°C rating

At +125°C, 50% of the 85°C rating

**Voltage Test:**

200% of rated voltage for 1 minute

**Insulation Resistance:**

At +25°C, 50,000 Megohm-Microfarads, need not exceed 100,000 Megohms

At +85°C, 2,500 Megohm-Microfarads, need not exceed 5,000 Megohms

At +105°C, 1,000 Megohm-Microfarads, need not exceed 2,000 Megohms

At +125°C, 10 Megohm-Microfarads, need not exceed 150 Megohms

**MAXIMUM PULSE RISE TIME:**

Capacitor Length Inches	Rise Time dv/dt (V/ $\mu$ s)				
	50 VDC	100 VDC	200 VDC	400 VDC	600 VDC
0.450	-	1000	-	-	-
0.531	735	-	-	-	-
0.594	540	-	-	-	-
0.656	360	-	-	-	-
0.718	288	288	413	875	1563
0.750	275	-	-	-	-
0.812	252	-	-	-	-
0.844	-	219	268	620	1050
0.875	-	-	-	-	1018
0.969	-	-	217	-	-
1.000	-	-	180	475	764
1.062	161	-	-	-	-
1.250	-	127	160	329	515
1.375	124	-	-	-	-
1.562	-	114	137	310	359
1.625	110	-	-	-	-
1.750	-	-	124	290	-
1.875	100	-	110	-	-
1.937	-	100	-	250	344
2.125	75	-	-	-	316
2.375	-	90	100	185	261
2.625	-	74	90	-	234
3.062	-	-	83	-	-

**STANDARD RATINGS**

Capacitance µF	Capacitance Code	Voltage Code 050 50VDC/ 32VAC*		Voltage Code 100 100 VDC 63 VAC*		Voltage Code 200 200 VDC 126 VAC*		Voltage Code 400 400 VDC 200 VAC*		Voltage Code 600 600 VDC 220 VAC*	
		D	L	D	L	D	L	D	L	D	L
0.0010	102	-	-	-	-	.190	.450	.190	.718	.190	.718
0.0015	152	-	-	-	-	.190	.450	.190	.718	.190	.718
0.0022	222	-	-	-	-	.190	.450	.190	.718	.190	.718
0.0033	332	-	-	-	-	.190	.450	.190	.718	.205	.718
0.0047	472	-	-	-	-	.190	.450	.190	.718	.235	.718
0.0068	682	-	-	.190	.450	.190	.718	.190	.718	.240	.844
0.010	103	-	-	.190	.450	.190	.718	.200	.844	.270	.844
0.015	153	.190	.531	.190	.718	.190	.718	.230	.844	.315	.875
0.022	223	.200	.594	.190	.718	.190	.718	.265	.844	.375	.875
0.033	333	.210	.656	.190	.718	.190	.844	.315	.875	.395	1.000
0.047	413	.215	.718	.215	.718	.210	.844	.325	1.000	.400	1.250
0.068	683	.250	.718	.215	.844	.240	.844	.340	1.250	.455	1.250
0.10	104	.290	.750	.245	.844	.275	.969	.400	1.250	.470	1.562
0.15	154	.312	.812	.285	.844	.345	1.000	.405	1.562	.545	1.562
0.22	224	.315	1.062	.290	1.250	.355	1.250	.480	1.562	.590	1.937
0.33	334	.375	1.062	.325	1.250	.425	1.250	.650	1.750	.800	1.937
0.47	474	.430	1.062	.380	1.250	.440	1.562	.725	1.937	.890	2.125
0.68	689	.450	1.375	.455	1.562	.610	1.750	.750	2.375	.980	2.375
1.00	105	.500	1.375	.535	1.562	.710	1.875	.900	2.375	-	-
1.50	155	.640	1.625	.645	1.937	.730	2.375	-	-	-	-
2.00	205	.730	1.625	.715	1.937	.800	2.375	-	-	-	-
2.50	255	.750	1.875	.715	2.375	.834	2.625	-	-	-	-
3.00	305	.830	1.875	.770	2.375	.905	2.625	-	-	-	-
4.00	405	.850	2.125	.830	2.625	.945	3.062	-	-	-	-
5.00	505	.940	2.125	.915	2.625	-	-	-	-	-	-

Additional capacitance values, voltages, and tolerances are available upon request.

\* AC Voltage rating is at 60Hz. 1.4 x VRMS + VDC should not exceed the rated VDC.